

## Chapter 3: Review of Basic Vacuum Calculations

Before we go any further, some time should be spent on some of the vocabulary specific to vacuum technology.

**Vacuum:** from a practical sense, vacuum may be defined as the condition of a gas under less than atmospheric pressure.

**Table 3.1:** Vacuum ranges

Vacuum Description	Range
Low vacuum	25 to 760 Torr
Medium vacuum	$10^{-3}$ to 25 Torr
High vacuum	$10^{-6}$ to $10^{-3}$ Torr
Very high vacuum	$10^{-9}$ to $10^{-6}$ Torr
Ultrahigh vacuum	$10^{-12}$ to $10^{-9}$ Torr
Extreme Ultrahigh vacuum	below $10^{-12}$ Torr

Vacuum technology is based upon the creation of an environment in which a process (thin film deposition, electron beam welding, etc.) can be carried out. This normally implies that one remove air from a system to some acceptable sub atmospheric pressure by the use of some type of vacuum pumping equipment.

**Atmosphere:** The blanket of gases that surrounds the surface of the earth and extends outward to a distance of about 25 miles is referred to as "air" or "the atmosphere". This mixture of gases exerts a pressure that presses uniformly on all objects on the surface of the earth. This pressure is about 15 pounds per square inch at sea level.

**Table 3.2:** Composition of Dry Air

Gas	Partial Pressure [Torr]	Percent [by volume]
nitrogen	593	78.1
oxygen	159	20.9
argon	7.1	0.934
carbon dioxide	0.25	0.033
neon	$1.4 \times 10^{-2}$	0.0018
helium	$4.0 \times 10^{-3}$	0.00053
methane	$1.5 \times 10^{-3}$	0.0002
krypton	$8.6 \times 10^{-4}$	0.00013
hydrogen	$3.8 \times 10^{-4}$	0.00005
nitrous oxide	$3.8 \times 10^{-4}$	0.00005
xenon	$6.6 \times 10^{-5}$	0.0000087

## **Properties of Systems Under Vacuum**

If we remove some amount of atmospheric gas from a leak-free vessel we will have created an environment that is drastically different in many respects: mechanically, chemically and physically.

**Mechanical Effects of Vacuum:** Have you ever placed a half full 2 liter plastic soft drink container that is at room temperature into a refrigerator, and noticed later after it has cooled that its sides are distorted and pulled inwards? What you have inadvertently done is create a condition in which the internal pressure of the plastic container was reduced, causing its surface to buckle. Vacuum engineers are acutely aware of this phenomenon, and design vacuum vessels to be sturdy enough to withstand the external atmospheric pressure of 14.7 pounds per square inch (at sea level) in the absence of compensating internal pressure. Structures and components that are particularly susceptible to distortion under vacuum conditions include flat, unsupported surfaces, thin sections, and flexible lines or bellows.

### **Sample Problem:**

**3.1** Calculate the approximate total force that will be exerted on a 4" diameter glass view port used in a vessel under high vacuum conditions.

**Chemical Effects of Vacuum:** The removal of gases from a container will reduce the number of gas atoms that are available to interact with materials in the container. For this reason many materials that are hygroscopic (have a tendency to absorb water from the atmosphere) are stored under vacuum. Materials that readily oxidize are also often stored either under high vacuum, or in an inert atmosphere (nitrogen or argon gas) after the air has been removed from the storage vessel.

### **Sample Problem:**

**3.2** List as many reactive elements or compounds that you know of which you would consider storing under vacuum or inert gas conditions.

**Physical Effects of Vacuum:** Many of the physical properties of gases are strongly affected by the pressure of the gas. Thermal conductivity, electrical conductivity, propagation of sound, optical transmission, optical absorption are just a few. In addition to the effect of reduced pressure on the physical properties of gases, under vacuum solids and liquids also show markedly different behavior. Liquids, such as water, can be made to boil in a vacuum vessel without the application of heat. This occurs as soon as the vapor pressure of the water exceeds that of the vacuum environment.. Similarly, atoms of solid material under vacuum conditions will spontaneously leave the surface of the solid. The rate at which materials vaporize under vacuum is a function of the pressure in the system and the vapor pressure of the material. A more in-depth discussion of vapor pressure will be presented later.

### **Sample Problem:**

**3.3** We have suggested that physical changes in the thermal and electrical conduction of gases are brought about by a decrease in pressure. What are the trends

you would expect in these two physical characteristics as pressure is decreased from atmospheric? (Increase or decrease?)

### Gas Laws

Gases are composed of independent, randomly moving atoms or molecules that spontaneously expand to fill any container. The collective behavior of these atoms or molecules in a contained volume can be described when one knows any three of the four following quantities:

- 1. Pressure:** The force per unit area a gas exerts on its surroundings. (in our calculations we will use primarily Torr or atmospheres).
- 2. Volume:** The internal capacity of a container, or vessel. (Liters)
- 3. Temperature:** The temperature of a gas is a function of its kinetic energy, that is, how vigorously the gas atoms are vibrating. Temperature must be specified in terms of an absolute temperature scale. We will use the kelvin scale ( $K = ^\circ C + 273$ ).
- 4. Amount:** The number of gas atoms in a volume (can be in terms of atoms or moles). {A mole of material is  $6.02 \times 10^{23}$  particles}.

**Boyle's Law:** Under conditions of constant temperature, Boyle's Law gives the relationship between volume and pressure for a fixed quantity of gas.

$$P_1 \times V_1 = P_2 \times V_2$$

Let's do a thought experiment to demonstrate Boyle's Law. Imagine a system of two leak-free vessels as shown below.

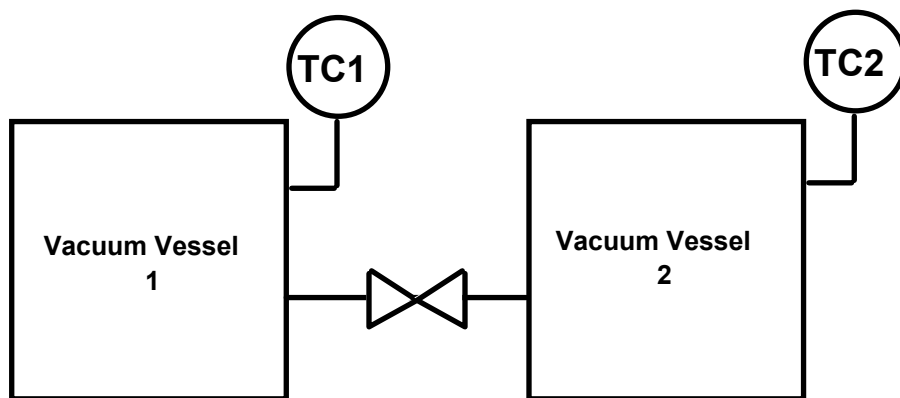

**Figure 3.1**

Assuming that the temperature is constant everywhere in our system, and that we can accurately measure the pressure in both vessels, we should be able to apply Boyle's law to calculate the volume of vacuum vessel 2.

If we know that at the beginning of our experiment the volume of vessel 1 is 120 liters, and the pressure of gas inside vessel 1 is 760 Torr, and that vacuum vessel 2 has been rough pumped to about 10 mTorr we can write:

$$P_1 = 760 \text{ Torr}$$

$$V_1 = 120 \text{ Liters}$$

Now, if we open the valve between vessels 1 and 2, and allow sufficient time for the system to equilibrate, we read pressures at TC1 and TC2 to be 500 Torr.

$$(760 \text{ Torr})(120 \text{ Liters}) = (500 \text{ Torr})(V_2 + 120 \text{ Liters})$$

Solving for  $V_2$  we find the second vessel has a volume of 62 liters (note that we include the tubulation to the right of the valve as part of the volume of vessel  $V_2$ ).

**Sample Problem:**

**3.4** What would be the volume of vessel 2 in figure 3.1 if the final pressure read on TC1 and TC2 was 350 Torr rather than 500 Torr?

**Charles' Law:** Under conditions of fixed volume and amount of gas, Charles' Law describes the relationship between the temperature and pressure of a gas.

$$\frac{P_1}{T_1} = \frac{P_2}{T_2}$$

If we raise the temperature in a closed leak-free vessel containing a gas initially at pressure  $P_1$ , the pressure will rise to  $P_2$ , following Charles' Law.

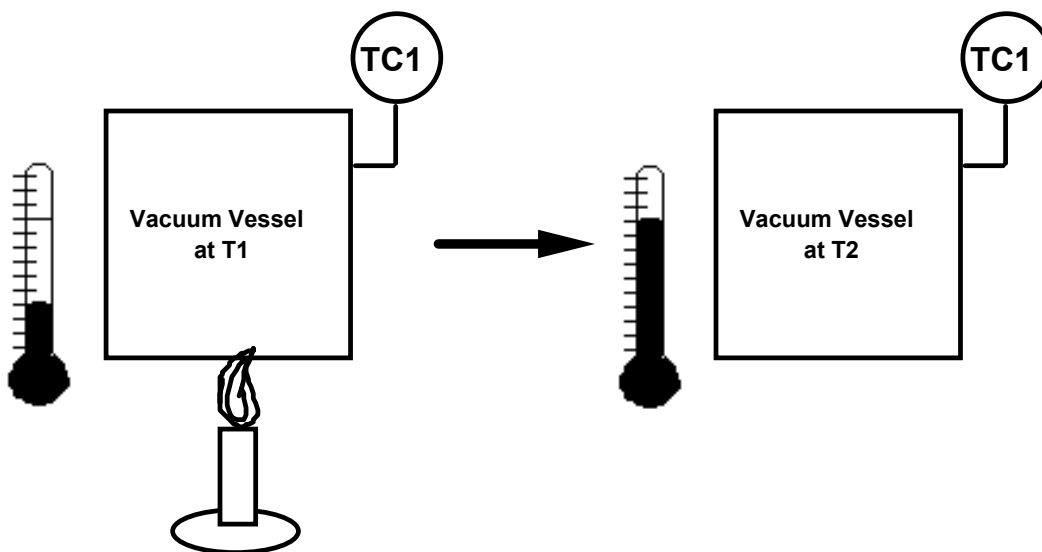

**Figure 3.2**

**Sample Problem:**

- 3.5 If the initial pressure and temperature of the leak-free vessel in figure 3.2 were 50 mTorr and 25 °C respectively, and the vessel was heated uniformly to 100 °C what would be the new pressure reading?

**The Ideal Gas Law:** The relationship between pressure, volume, amount of gas and temperature of gas for "ideal" gases is given by the Ideal gas law. Fortunately, most gases behave "ideally" under subatmospheric conditions.

$$PV = nRT$$

P= pressure [Atmospheres]

V=volume [Liters]

n=moles of gas [moles]

R=Ideal gas Law constant  
(0.08206 L-atm/K-mole)

T=absolute temperature [Kelvin]

**Sample Problem:**

- 3.6 If a 100 liter vessel at room temperature is evacuated to a pressure of 50 mTorr, how many moles of gas are in the vessel? How many molecules is this? How many molecules per cubic centimeter is this?

**Table 3.3:** Quantities, Symbols and Units

Quantity	Symbol	Unit
length	L	cm, m
area	A	cm <sup>2</sup> , m <sup>2</sup>
volume	V	cm <sup>3</sup> , m <sup>3</sup>
diameter	d	cm, m
mass	m	g
time	t	sec,minute,hour
amount of substance	n	mole
thermodynamic temperature	T	k
speed of particles in flow	c	cm/s,m/s
dynamic viscosity	$\eta$	kg/m-s
thermal conductivity	$\lambda$	W/m-k
pressure (gas)	P	Torr, mTorr
molar heat capacity (const press)	C <sub>p</sub>	J/k-n
molar heat capacity (const volume)	C <sub>v</sub>	J/k-n
Reynolds number	RE	
Knudsen number	Kn	
Avogadro constant	N <sub>A</sub>	6.02 x 10 <sup>23</sup> particles
Gas Law constant	R	0.059 L-atm/k-n
velocity	v	cm/s, m/s
mass flow rate	q <sub>m</sub>	g/s, kg/s
impingement rate	Z <sub>A</sub>	cm <sup>-2</sup> -s <sup>-1</sup>
volume impingement rate	Z <sub>v</sub>	cm <sup>-3</sup> -s <sup>-1</sup>

volumetric flow rate	$q_v$	$\text{cm}^3/\text{s}, \text{m}^3/\text{s}$
quantity of gas (PV value)	G	Torr-L
pumping speed (Volumetric flow)	S	L/s
mass flow rate	Q	Torr-L/s
conductance	C	L/s
leak rate	$q_l$	Torr-L/s
molecular weight	M	g/n
mean free path	L	cm
number density of particles	N	$\text{cm}^{-2}$

### **Kinetic Description of the Behavior of Gases**

As the name may suggest, the kinetic theory of gases has to do with describing how gases behave under the influence of external forces that induce motion. There are four basic assumptions that provide the foundation of the kinetic theory of gases:

- 1) Gases are comprised of a large number of extremely small particles (atoms or molecules).
- 2) These gas molecules are in constant, rapid motion in a chaotic manner.
- 3) The distances between individual gas molecules are large compared with the diameter of the molecules.
- 4) The molecules exert no force on one another, or on the walls of a container except during collisions.

**Velocity of Gas Molecules:** The speed at which gas molecules travel is independent of pressure, but is a function of the temperature and molecular weight of the gas.

$$\bar{v} = 1.455 \times 10^4 \sqrt{\frac{T}{W_m}} \left[ \frac{\text{cm}}{\text{sec}} \right]$$

$\bar{v}$  = average molecular velocity [cm/sec]  
 T = absolute temperature [K]  
 M = molecular weight of gas [grams/mol]

#### **Sample Problem:**

- 3.7 Calculate the velocity of a nitrogen molecule at 100 °C. (to convert from centigrade to kelvin, add 273).

**Mean Free Path:** The distance a gas molecule can travel (on the average) is a function of total pressure and the diameter of the gas molecules.

$$L[\text{cm}] = \frac{1}{\sqrt{2PN}d^2}$$

L = mean free path [cm]  
 N = number density of particles [ $\text{cm}^{-3}$ ]  
 d = molecular diameter [cm]  
 P = pressure, Torr

**Sample Problem:**

**3.8** For a vacuum system at room temperature having a volume of 50 liters, and containing nitrogen gas at a pressure of  $5 \times 10^{-6}$  Torr, find the number density,  $N$ , and the mean free path,  $L$  {the molecular diameter of  $N_2$  is  $3.8\text{\AA}$  or  $3.8 \times 10^{-8}$  cm }

For most clean vacuum systems the majority of the gas load may be assumed to be nitrogen, and at room temperature the following approximation may be used to calculate the mean free path for  $N_2$  molecules:

$$L = \frac{5.0 \times 10^{-3}}{P}$$

$L$  = mean free path [cm]  
 $P$  = pressure [Torr]

**Collisions of Gaseous Species:** Gas molecules travel in straight lines between collisions and tend to strike all exposed internal surfaces of the vessel in which they are contained. Pressures that we measure using various types of gauges (more on this in chapter 5) are the result of the collective impacts of these gas molecules on the inner surfaces of the containing vessel. The rate of impact (or impingement rate) of gas molecules per second per square centimeter of surface area is a function of the speed of the molecules and the gas density

$$I = \frac{Nv}{4} \left[ \frac{1}{\text{cm}^2 - \text{sec}} \right]$$

$N$  = molecular density, [ $\text{cm}^{-3}$ ]  
 $v$  = molecular velocity [cm/sec]  
 $I$  = impingement rate [ $\text{cm}^{-2} - \text{sec}^{-1}$ ]

Usually, the quantities that we can easily measure are pressure and temperature, so, the same equation expressed in terms of these units is:

$$I = 3.5 \times 10^{22} \frac{P}{\sqrt{W_m T}} \left[ \frac{1}{\text{cm}^2 - \text{sec}} \right]$$

**Sample Problem:**

**3.9** What is the impingement rate for nitrogen molecules on the inner surface of a vacuum vessel having a pressure of  $5 \times 10^{-6}$  Torr and a temperature of  $25^\circ\text{C}$ ? What is  $I$  for the same system at  $5 \times 10^{-9}$  Torr?

**Motion of Gas Molecules:** As collisions occur between gas molecules and the inner exposed surfaces of a vessel, the molecules are "diffusely" reflected, that is there is no relationship between the arrival angle and the departure angle following a collision. The angle of departure from a planar surface has been studied and was observed to follow a cosine distribution as shown in figure 3.4

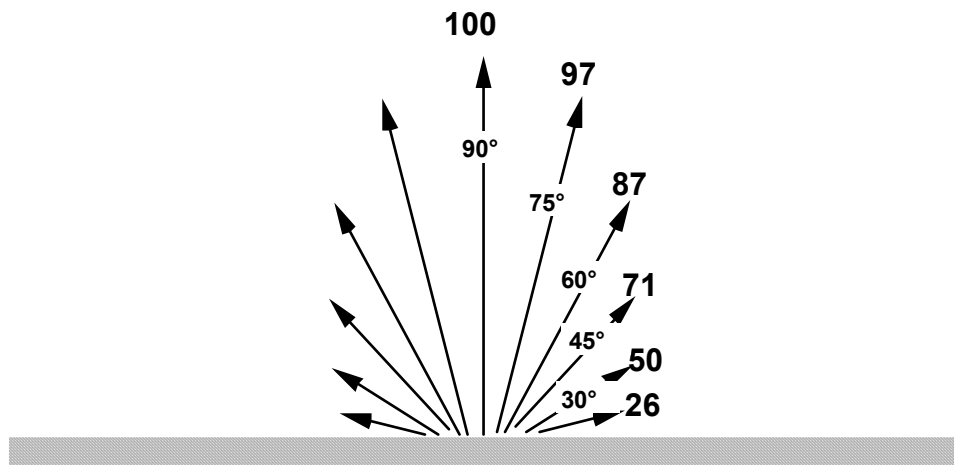

**Figure 3.4:** Cumulative probability of departure angles of gas molecules departing a smooth surface. For example, 50% of particles will depart with an angle of 30° or less.

**Flow of Gas Through an Orifice:** Let's do another thought experiment. Imagine a leak free vacuum system comprised of two vessels separated by a closed valve. One vessel contains nitrogen gas at a pressure of  $5 \times 10^{-5}$  Torr and the other vessel is under extreme high vacuum ( $5 \times 10^{-10}$  Torr). Both vessels are at room temperature. If we suddenly open the valve what will happen during the pressure equilibration time? Only those molecules that randomly impinge {molecular flow, right?} upon the opening between the vessels will leave the vessel at higher pressure and move into the vessel at lower pressure. Let me make the point clear by stating the reverse: those molecules in the vessel at initially higher pressure that don't impinge upon the opening between the vessels can not leave the vessel they are in. What this suggests is that the flow rate for gas molecules leaving a vessel is a function of the collision rate of molecules per unit surface area. The *number* of gas molecules leaving is:

$$I = \frac{Nv}{4} \left[ \frac{1}{\text{cm}^2 - \text{sec}} \right]$$

The *volume* of gas leaving may be calculated by dividing the number of gas molecules leaving by the number of molecules per unit volume (N)

The *volumetric flow rate* of gas through a hole is independent of the gas pressure; but depends on the gas velocity,  $v$ , which is a function of temperature and molecular weight.

For the situation in which the mean free path of gas molecules is greater than the diameter of the opening in the wall of the chamber, the volumetric flow rate (s) is given by:



$$S = \frac{v}{4} = 1.455 \times 10^4 \sqrt{\frac{T}{W_m}}$$

S= volumetric flow rate [L/s]  
 T= absolute temperature [K]  
 W<sub>M</sub>= molecular weight [g/mole]

### **Modes of Gas Flow Under Various Vacuum Conditions**

The three modes of gas flow that we will be interested in describing are: turbulent (or viscous), laminar (or transition) and molecular flow.

The flow regime created when air is induced to move through cylindrical tubes is a function of the tube diameter and the average pressure.

$$D\bar{P} \geq 0.18$$

$$D\bar{P} \leq 0.004$$

$$0.004 \leq D\bar{P} \leq 0.18$$

For these equations, D is the inside diameter, in inches, and P<sub>bar</sub> is the average pressure in Torr

Criteria for *Viscous* Flow Regime

Criteria for *Molecular* Flow Regime

Criteria for *Transition* Flow Regime

Upon initiating a pump down, the flow of gas molecules is often turbulent, exhibiting eddies and currents much like a raging rapid.

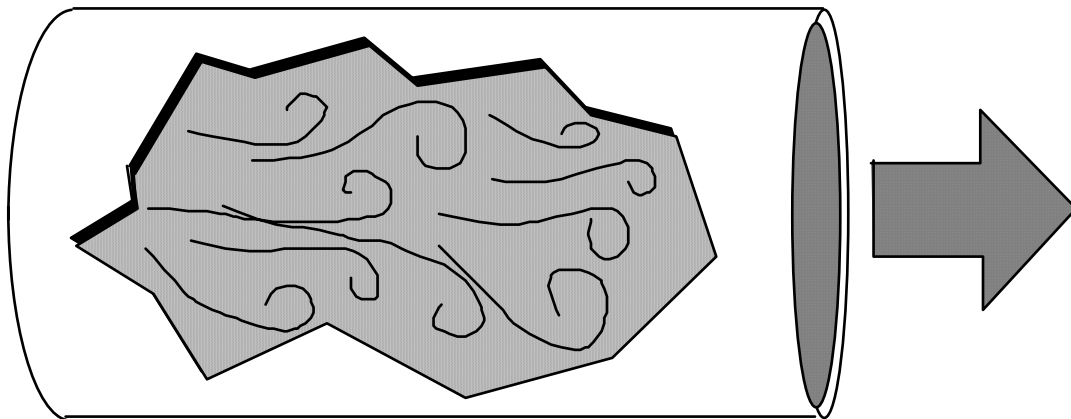

**Figure 3.5** *Viscous* flow of gas molecules during pump down.

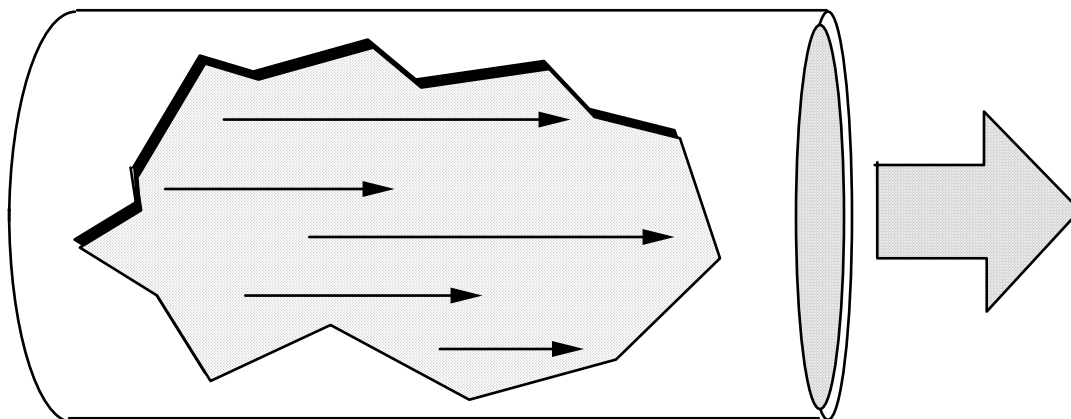

**Figure 3.6** Gas molecules in *transition* flow conditions. Mean free path is roughly equivalent to the pipe diameter.

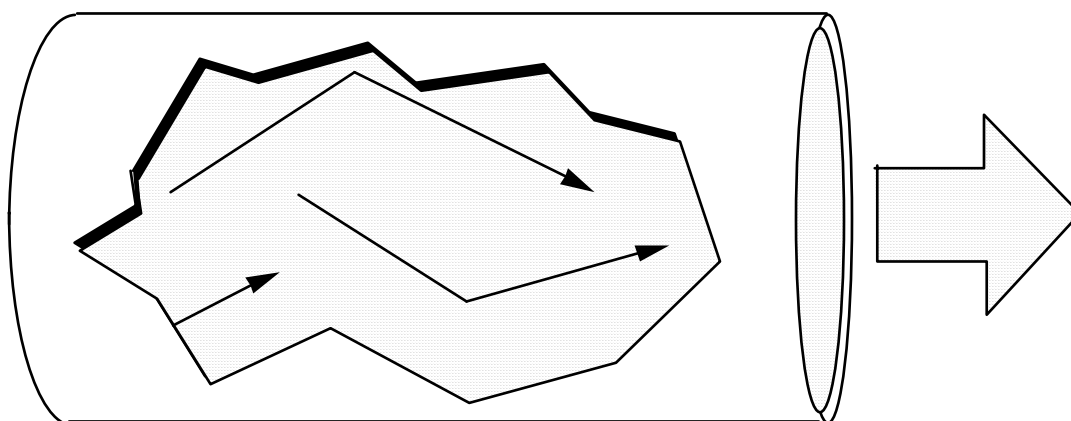
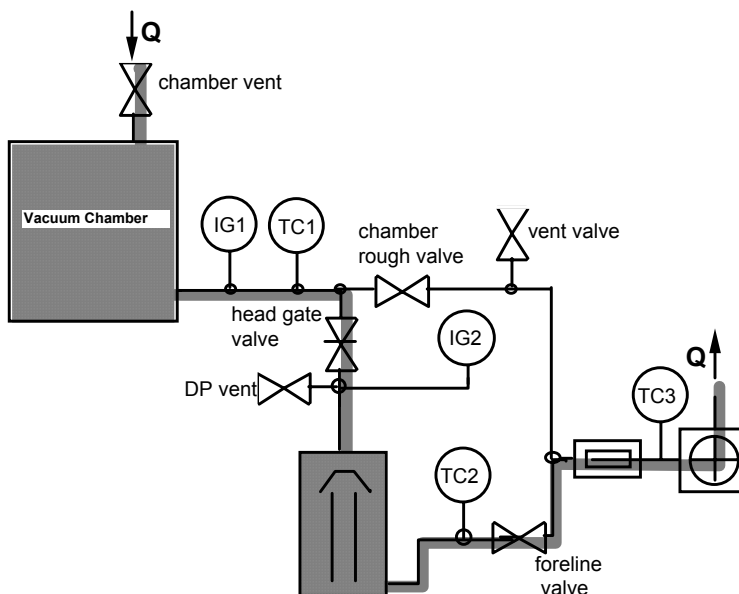

**Figure 3.7** Gas molecules in *molecular* flow conditions. Mean free path is greater than 1.5 times the pipe diameter.

### **Gas Flow Rates**

**Volumetric:** Flow rate (S) is the volume amount of gas that passes by a point per unit time. Examples of units are: liters/second or cubic feet/ minute. The volumetric flow rate may be considered to be the pumping speed of a system at a specified point in the conductance path.

**Quantitative:** Flow rate (Q) is the amount of gas that passes by a point per unit time. Units are: Torr-liters/second. The quantitative flow rate is also referred to as the throughput, or mass flow, and is constant everywhere in the vacuum system, unless gas is leaking or is being captured or condensed along the path.



**Figure 3.8** Gas flowing through a vacuum system beginning at the inlet to the vacuum vessel and exiting at the exhaust of the roughing pump. At all locations in the vacuum circuit the quantitative flow rate (Q) is the same.

$$Q = SP$$

Q= quantitative flow rate [torr-liters/sec.]  
 S= volumetric flow rate [liters/sec]  
 P= pressure [Torr]

**Conductance in a Vacuum System:**

Gases moving through conductance elements (pipes, tubes, vessels, and orifices) in a vacuum system encounter resistance to their motion. At higher pressures, this resistance is a function pressure difference and geometry of the conductance element.

$$Z = \frac{P_1 - P_2}{Q}$$

Z= resistance [sec/liter]  
 P= pressure [Torr]  
 Q=flow rate [Torr-L/s]

Conductance is the inverse of resistance and therefore,

$$C = \frac{1}{Z} = \frac{Q}{P_1 - P_2}$$

C= conductance [liter/sec]

Even very simple vacuum systems are comprised of many conductance elements, some are connected in series, some in parallel. Let's examine how to calculate the effect of various components in simple systems.

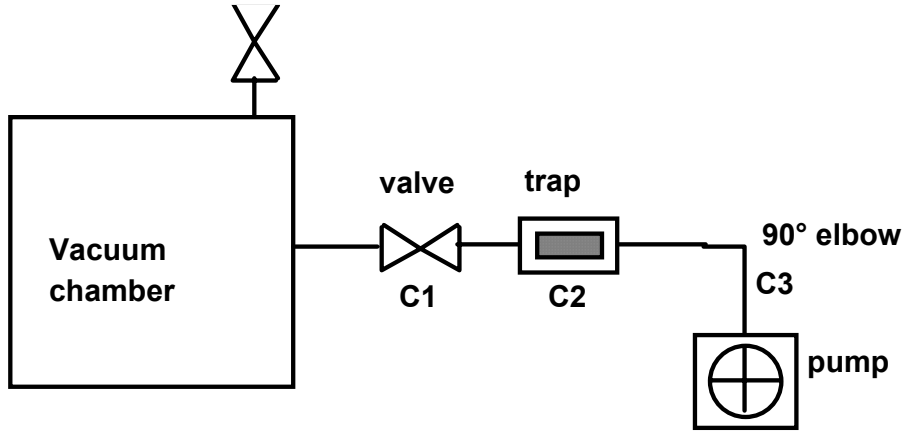

**Figure 3.9** Conductance elements connected in Series

$$\frac{1}{C_T} = \frac{1}{C_1} + \frac{1}{C_2} + \frac{1}{C_3} + \dots = \sum \frac{1}{C_i}$$

$C_T$  = total conductance for elements  $C_1$ ,  $C_2$ ,  $C_3$ ...that are connected in Series

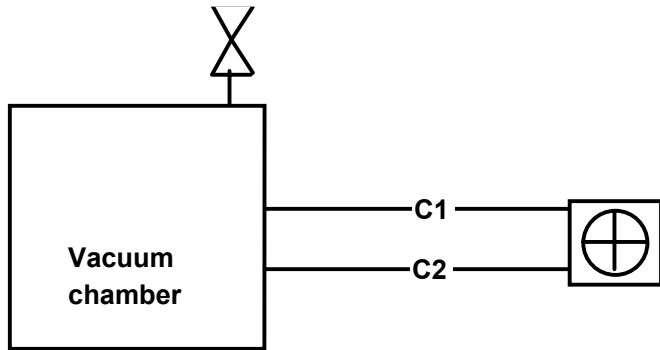

**Figure 3.10** Conductance elements connected in parallel.

$$C_T = C_1 + C_2 + C_3 + \dots = \sum C_i$$

$C_T$  = total conductance for elements  $C_1$ ,  $C_2$ , etc. which are connected in Parallel in figure 3.10

**Sample Problems**

**3.10** For the vacuum system shown in figure 3.9, if  $C_1 = 50$  L/s,  $C_2 = 100$  L/s and  $C_3 = 100$  L/s what is the total conductance of the three elements?

**3.11** In figure 3.10, if  $C_1$  and  $C_2$ , have the same values as in the previous problem, what is the net conductance of the assembly?

### Calculation of Conductance

In this section we will present several "general use" formulas for calculation of conductance's under commonly encountered situations.

**Viscous Flow:** For the situation in which the mean free path,  $L$ , is approximately the same as the diameter of the conductance element; the throughput,  $Q_v$ , for dry air is given by:

$$Q_v = \frac{3000\bar{P}D^4}{L} (P_1 - P_2) \left[ \frac{\text{Torr-liters}}{\text{sec}} \right]$$

$P$  = average pressure  
 $(P_1 + P_2)/2$   
 $D$  = tube diameter [inches]  
 $L$  = tube length [inches]

Conductance for this situation is given by:

$$C_v = \frac{Q_v}{(P_1 - P_2)} \qquad C_v = \frac{3000PD^4}{L} \left[ \frac{\text{liters}}{\text{sec}} \right]$$

{Note: conductance element length and diameter ( $L$  and  $D$ , respectively) are in inch units.}

**Molecular Flow:** For the situation in which the mean free path of molecules is much larger than the diameter of the conductance element, the relationships for throughput,  $Q$  and conductance,  $C_m$  are given by:

$$Q_m = \frac{80D^3}{L} (P_1 - P_2)$$

$$C_m = \frac{Q_m}{(P_1 - P_2)} \qquad C_m = \frac{80D^3}{L}$$

Now let's apply this information to the calculation of pumping speeds in a simple vacuum system.

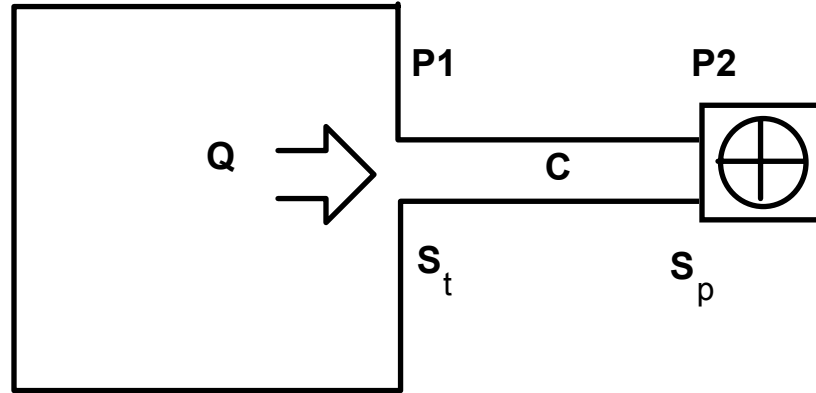

**Figure 3.11:** A simple vacuum system.

At any location in the vacuum circuit the volumetric flow rate or pumping speed at that point can be found if we know the pressure at that point, the pressure at the pump, and the conductance of the path connecting these two. At the chamber side of the system  $P_1 = Q/S_t$ , and similarly at the pump side,  $P_2 = Q/S_p$ . We will make use of the relationship between mass flow ( $Q$ ), pressure drop ( $P_1 - P_2$ ), and conductance ( $C$ ):

$$Q = (P_1 - P_2)C$$

Substituting  $Q/S_t$  for  $P_1$  and  $Q/S_p$  for  $P_2$  we get:

$$Q = \left( \frac{Q}{S_t} - \frac{Q}{S_p} \right) C$$

Dividing both sides of the equation by  $QC$  we get:

$$\frac{1}{C} = \frac{1}{S_t} - \frac{1}{S_p}$$

Now we can solve for  $S_t$ , the pumping speed at the chamber orifice.

**Sample Problem:**

**3.12** For the simple vacuum system pictured in figure 3.11, calculate the pumping speed at the chamber if the pump has a speed of 200 L/s, the pressure at the vacuum pump is  $5 \times 10^{-6}$ , and the conductance element is a tube 30" long by 2" in diameter.

Conductance of apertures will become important when performing vacuum system calculations when tube diameters abruptly change diameter by a factor of two or more (see picture below).

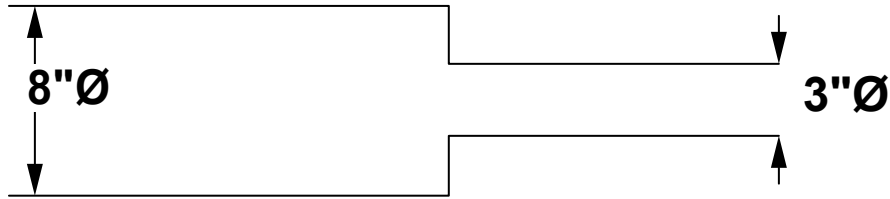

While accurate equations for aperture flow are complex in the viscous flow regime, this approximation is often reasonably valid:

$$C_v = 130A$$

A = Area of circular or nearly square aperture.  
 $C_v$  = Conductance in l/s in viscous regime

In the molecular flow regime the following is valid for Nitrogen near room temperature:

$$C_m = 75A$$

A = Area of circular or nearly square aperture.  
 $C_m$  = Conductance in l/s in molecular regime

Before purchasing components for and building an expensive vacuum system, calculations are generally performed that provide information as to the amount of time that will be needed to evacuate the vacuum system to a certain pressure. Typically the calculation is broken (partitioned) into five or more "pressure intervals" and at each interval the conductance of the tubulation between the vessel and pump is calculated. The pump speed delivered to the vessel is calculated, and finally, the time to pump from the upper pressure limit of the interval to the lower pressure limit of the interval is computed. The calculation is performed in segments because both conductance (in viscous flow) and pump speed change as pressure decreases. Plots on the following page give the general behavior of tube conductance and vacuum pump speed as a function of pressure.

$$t = \frac{V}{S_t} \ln \left( \frac{P_1}{P_2} \right)$$

t = time to pump from pressure  $P_1$  to  $P_2$ , (sec)  
 V = Chamber volume, incl. tubulation, (liters)  
 $S_t$  = delivered pump speed, (liters/second)

**Pressure Interval 1:** Time required to pump from 760 Torr to 100 Torr.

- Calculate the conductance of the tube between the pump and vessel (be sure to check for viscous or molecular flow conditions).
- Use a pump efficiency curve to determine the volumetric pumping speed of the pump for the pressure interval of interest.
- Calculate the delivered pump speed.
- Calculate the time to pump from  $P_1$  to  $P_2$ .

Repeat steps A through D for the following pressure intervals:

**Pressure Interval 2:** Time required to pump from 100 Torr to 10 Torr.

**Pressure Interval 3:** Time required to pump from 10 Torr to 1 Torr.

**Pressure Interval 4:** Time required to pump from 1 Torr to 0.1 Torr.  
**Pressure Interval 5:** Time required to pump from 0.1 Torr to 0.01 Torr.

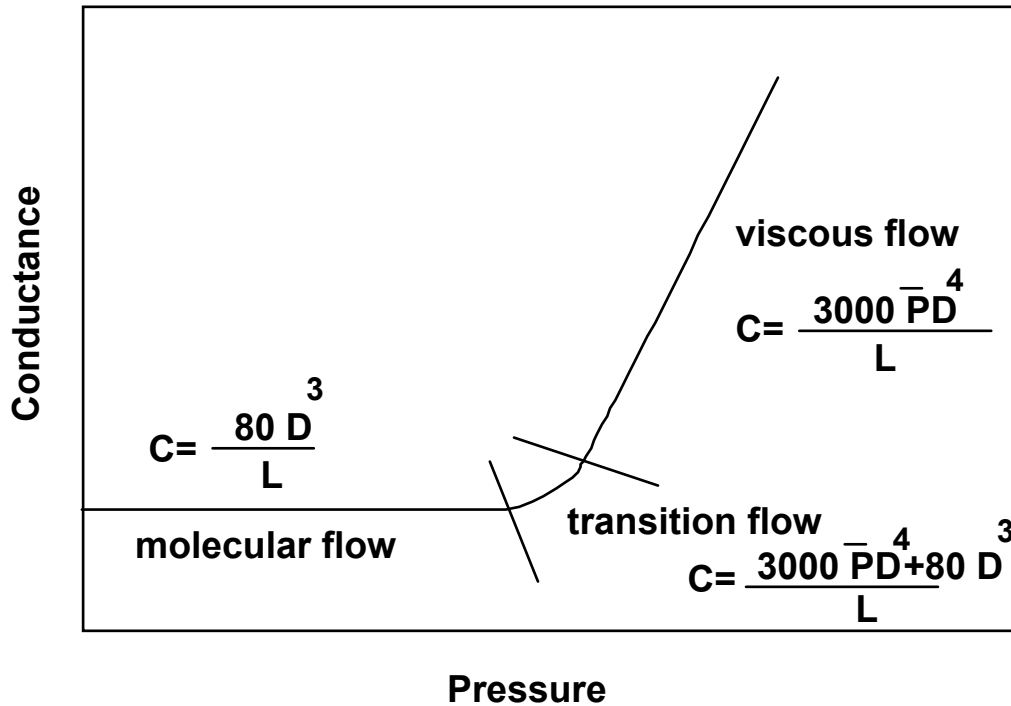

**Figure 3.1** Conductance vs. pressure for dry air being pumped through a tube of circular cross section.

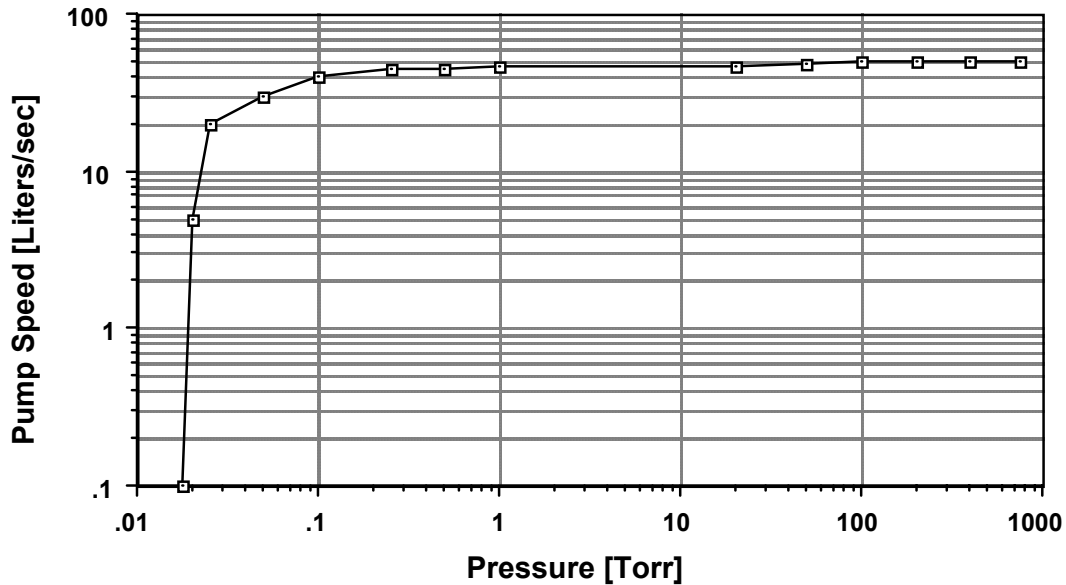

**Figure 3.2** Pump speed vs. pressure for an oil sealed mechanical pump.



### For Further Reading:

#### Kinetic theory of gases-

High Vacuum Technology, Hablanian, Marsbed, M., Marcel Dekker, INC., New York, New York. 1990.

#### Vacuum system calculations-

High Vacuum Technique, Yarwood, J., Chapman and Hall, Ltd., 11 New Fetter lane, London, 1967.

High Vacuum Technology, Hablanian, Marsbed, M., Marcel Dekker, INC., New York, New York. 1990.

A User's Guide to Vacuum Technology, O'Hanlon, John F. John Wiley & Sons New York, New York. 1980.

Practical Vacuum Systems, LaPelle, Roland R. , McGraw-Hill Book Co. New York, New York. 1972.

### Answers to Chapter 3 Sample Problems

**3.1**  $4" \text{ } \varnothing \text{ view port has a surface area} = \pi \times r^2 = 3.14 \times 4 = 12.6 \text{ sq. in.}$   
 $12.6 \text{ sq. in} \times 14.7 \text{ lbs/sq. in} = 185 \text{ lbs.}$

**3.2** Sodium (reactive metal), pure iron (oxidizes rapidly in moist air), and lithium (reactive metal).

**3.3** As pressure decreases, thermal conductivity and electrical conductivity of air should both decrease.

**3.4** 140 liters.

**3.5** 63 mTorr.

**3.6**

A. Solve for the number of moles, n in the vessel.

step 1: convert pressure  $50 \text{ mTorr}/760 \text{ Torr} = 6.58 \times 10^{-5} \text{ atm}$

step 2: convert temperature  $25 \text{ }^\circ\text{C} + 273 = 298 \text{ k}$

step 3:  $PV = nRT$   $(6.58 \times 10^{-5} \text{ atm})(100 \text{ L}) = n(0.08206 \text{ L-atm/k-mol})(298 \text{ k})$

$n = 2.69 \times 10^{-4} \text{ moles of gas molecules.}$

B. Solve for the number of molecules in the vessel.

{there are  $6.02 \times 10^{23}$  molecules per mole}

$(2.69 \times 10^{-4} \text{ moles})(6.02 \times 10^{23} \text{ molecules per mole}) = 1.62 \times 10^{20} \text{ molecules.}$

C. Solve for the number of molecules per cubic centimeter.

$(1.62 \times 10^{20} \text{ molecules}/100 \text{ liters})/100 =$

$1.62 \times 10^{18} \text{ molecules/liter.}$

$(1.62 \times 10^{18} \text{ molecules/liter})/1000 \text{ cubic centimeters/liter} =$

$1.62 \times 10^{15} \text{ molecules/cubic centimeter}$

**3.7**  $T = 373 \text{ k}$ ,  $M = 28 \text{ g/mole}$ .  $V = 53,100 \text{ cm}^3/\text{sec}$ .

**3.8** Given:  $T=25\text{ }^{\circ}\text{C}$ ,  $V=50\text{ liters}$ ,  $P=5 \times 10^{-6}\text{ Torr}$ .

A. Solve for the number of moles of gas, using the ideal gas law.

step 1: convert pressure  $(5 \times 10^{-6}\text{ Torr})/760\text{ Torr} = 6.7 \times 10^{-9}\text{ atm}$ .

step 2: convert temperature  $25\text{ }^{\circ}\text{C} + 273 = 298\text{K}$

step 3:  $PV=nRT$

$(6.7 \times 10^{-9}\text{ atm})(50\text{ L})=n(0.08206\text{ L-atm/k-mol})(298\text{K})$

$n = 1.36 \times 10^{-8}\text{ moles of gas molecules in 50 liter volume.}$

B. Calculate the number of molecules in the 50 liter volume.

$(1.36 \times 10^{-8}\text{ moles})(6.02 \times 10^{23}\text{ molecules per mole}) = 8.2 \times 10^{15}\text{ molecules.}$

C. Calculate the number of molecules in one cubic centimeter.

$(8.2 \times 10^{15}\text{ molecules}/50\text{ L})/50\text{ L} = 1.64 \times 10^{14}\text{ molecules/L}$

$(1.64 \times 10^{14}\text{ molecules/L})/1000\text{ cubic centimeters/L} =$

$N = 1.64 \times 10^{11}\text{ molecules/cubic centimeter.}$

D. The mean free path,  $L =$

**3.9**  $l = 1.92 \times 10^{15}\text{ molecules/sec-cm}^2$ .

**3.10**  $C = 25\text{ L/s}$ .

**3.11**  $C = 150\text{ L/s}$

**3.12** First calculate the conductance of the conductance element. given: tube is 30" long, 2" in diameter, assume molecular flow.  $C = 80 \times (4")^3/30" = 21.33\text{ L/s} = 171\text{ L/s}$ .

Then use  $1/S_1 = 1/C + 1/S_2$  to solve for  $S_1$ .  $S_1 = 92\text{ L/s}$ .

### **Laboratory Exercise 3.1:**

#### **Measurement of pumping speed at the vacuum chamber**

**Experimental set-up:** Select a working rotary vane mechanical pump and the appropriate gages, tubulation, and fittings to assemble a vacuum system as shown in figure 3.13 First, assemble the system with a short conductance element between the chamber and pump. Calculate the conductance of the element using formulas discussed in this chapter. Evacuate the chamber, allowing the mechanical pump to achieve its base pressure. Record  $P_1$  and  $P_2$ , and using the calculated value of  $C$ , and the manufacturer's value of pump speed, solve for the pumping speed at the chamber. Repeat the experiment for a much longer conductance element of the same diameter.

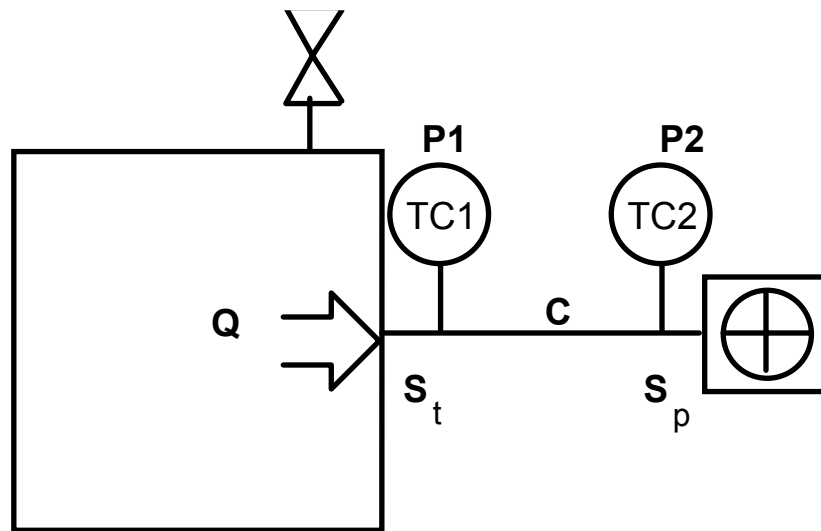

**Figure 3.13** Experimental setup for measurement of pumping speed at the vacuum chamber.

**Discussion:**

Did the change in conductance element length between the pump and chamber cause the expected change in pumping speed as measured at the chamber? Why or why not?