



ISO 9001:2008



TGA TRÄGERGESELLSCHAFT FÜR AKKREDITIERUNG
GERMAN ASSOCIATION FOR ACCREDITATION GMBH

TGA-ZM-02-06-00

VACUUM COMPONENTS

Total Vacuum Solutions

We are one of the leading company of vacuum pump distributor including pump & system assembly, maintenance and services needed by those related with in domestic and overseas as well. The range of our customers are reaching to the research, technical and industrial organization and has good reputations in our products, favorable terms and services.

As above mentioned, our various products including Dry pump, Rotary pump, ISP series, Glove box, Liquid ring pump, vacuum system and components of vacuum pumps with durability, efficiency, strength & reliable competitive price and good services. For further information, you are being invited to our web site: www.woovac.com

In order to diversify our existing market, we are effort and in the anxious to develop our business activity by supplying our high quality products on favorable terms.

Hoping for a business connection in the future and having an opportunity to be of service to you. We would appreciate of your highly concerning and attention to us with your favorable reply.

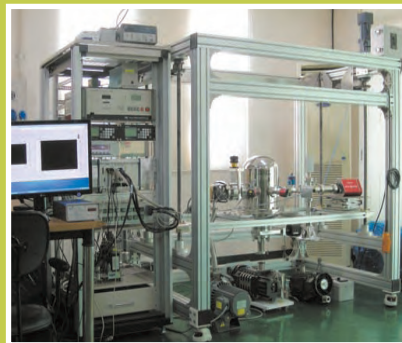

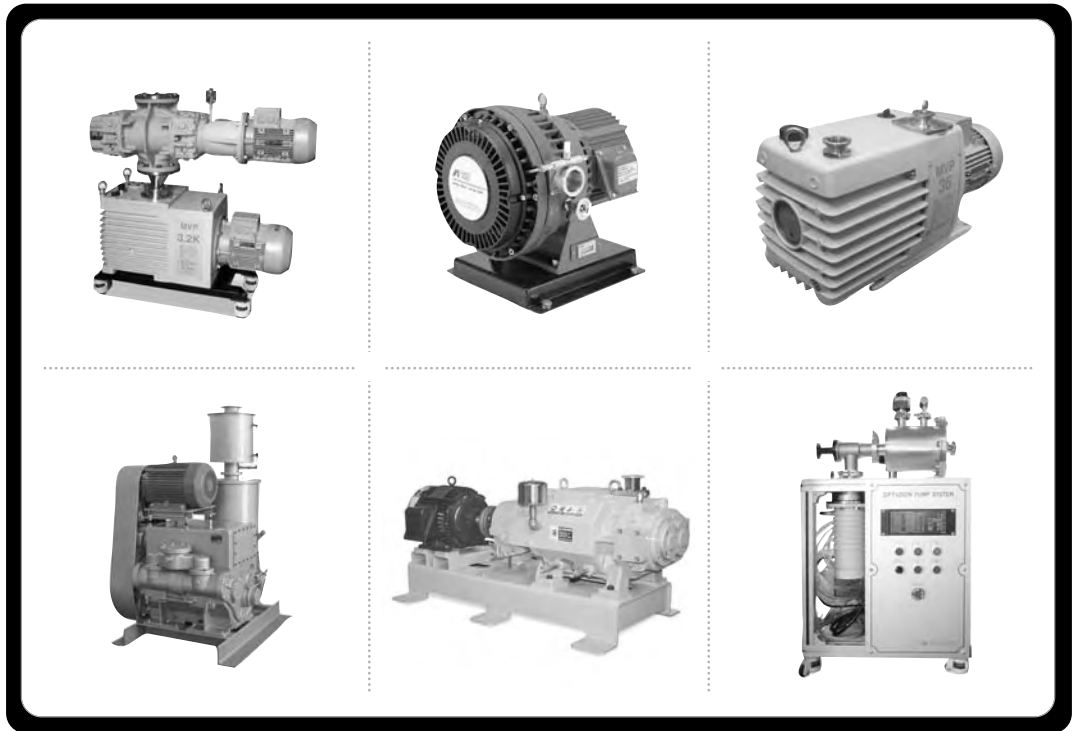

CONTENTS

Oil Rotary Pumps	4
Dry Pumps	9
Water Ring Pumps	16
Booster Pumps	18
Diffusion Pumps	20
Booster Pump Systems	21
Diffusion Pump Systems	22
Vacuum Systems	23
System Layout	24
Vacuum Gauges	28
Mass Flow Controller	34
Vacuum Pump Accessories	35
Vacuum Valves	36
Vacuum Accessories	43
Woosung Vacuum System Line-up	51

OIL ROTARY PUMPS

WSVP Series

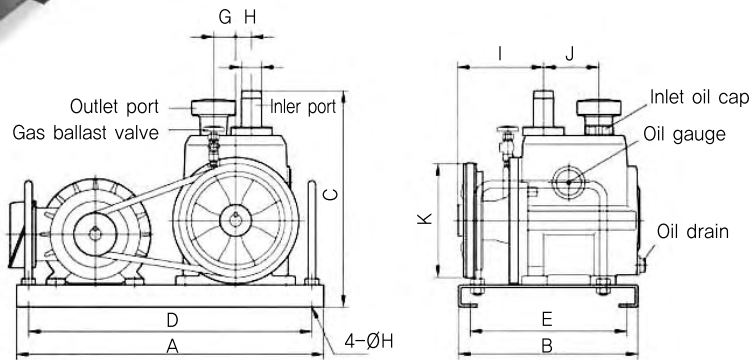

Technical Data

MODEL		WSVP 9018	WSVP 9030	WSVP 9060
Displacement speed (ℓ /min)	60Hz	180	300	600
	50Hz	150	250	500
Ultimate pressure (Torr)	With gas ballast	1×10^{-2}	1×10^{-2}	1×10^{-2}
	Without gas ballast	5×10^{-4}	5×10^{-4}	5×10^{-4}
Inlet port		Ø32	Ø32	Ø46
Outlet port		PF 1	PF 1 1/4	PF 1 1/2
Power requirements(Kw)		0.4	0.75	0.75
Rotational speed(R.P.M)		600	600	600
Oil capacity(ℓ)		1.8	2.2	4
Weight(including motor) kg		32(50)	35(60)	51(80)

Outside Dimension

(UNIT : mm)

MODEL	A	B	C	D	E	F	G	H	I	J	K	L
WSVP 9018	488	285	342	450	200	Ø32	35	25	135	88	Ø171	Ø13
WSVP 9030	545	310	365	515	274	Ø32	40	30	145	100	Ø171	Ø13
WSVP 9060	610	350	424	580	310	Ø46	50	35	171	110	Ø210	Ø13

OIL ROTARY PUMPS

WSSR-V Series

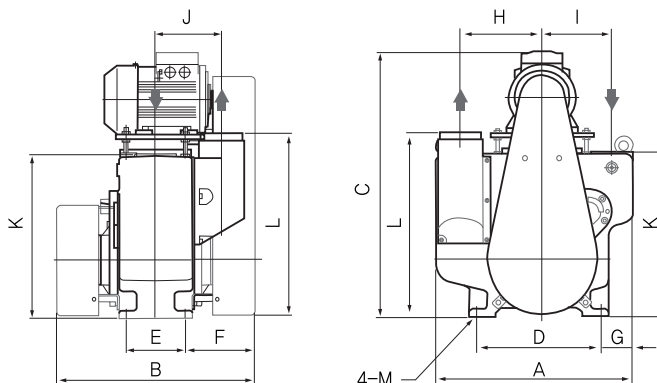
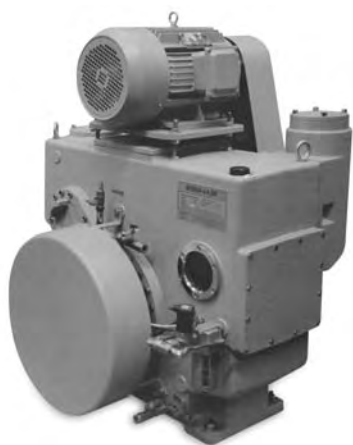

Technical Data

MODEL	WSSR-V1.5K	WSSR-V2.5K	WSSR-V4.8K	WSSR-V7.5K	WSSR-15K
Displacement speed (ℓ/min)	1500	2500	4800	7500	15000
Ultimate pressure (Torr)	5×10^{-3}	5×10^{-3}	5×10^{-3}	5×10^{-3}	5×10^{-3}
Inlet port	VG50	VG80	VG80	VG100	VG150
Outlet port	VG50	VG50	VG65	VG100	VF125
Motor power(Kw)	2.2	3.7	7.5	11	22
Rotational speed of pump (R.P.M)	410	410	410	380	370
Oil filling(ℓ)	5	8	17	29	55
Weight(include motor) kg	236	324	555	791	1064(1245)
V-Belt(Size/Qty)	3V-590/3	3V-640/3	3V-810/4	3V-970/5	C-121/6
Cooling water(ℓ)	-	5	5	7	-

Outside Dimension

(UNIT : mm)

MODEL	A	B	C	D	E	F	G	H	I	J	K	L	M
WSSR-V1.5K	565	570	744	360	170	200	90	235	200	190	470	528	Ø14
WSSR-V2.5K	668	600	808	450	180	210	95	277	220	205	510	569	Ø20
WSSR-V4.8K	803	714	1034	580	230	242	105	326	290	251	675	750	Ø20
WSSR-V7.5K	900	816	1187	670	280	268	125	364	318	296	765	857	Ø20

OIL ROTARY PUMPS

MVP Series (6~90m³/h)

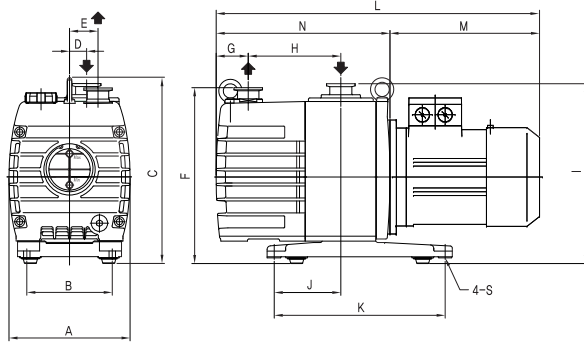

Technical Data

Description		UNIT	MVP6	MVP12	MVP24	MVP36	MVP60	MVP90
Displacement speed	60Hz	m ³ /h	6	12	24	36	60	90
		ℓ /min	100	200	400	600	1000	1500
	50Hz	m ³ /h	5	10	20	30	50	75
		ℓ /min	80	170	335	500	830	1250
Ultimate pressure	Gas ballast C	Torr	5×10 ⁻⁴	5×10 ⁻⁴	5×10 ⁻⁴	5×10 ⁻⁴	5×10 ⁻⁴	5×10 ⁻⁴
	Gas ballast I	Torr	5×10 ⁻³	5×10 ⁻³	5×10 ⁻³	5×10 ⁻³	5×10 ⁻³	5×10 ⁻³
	Gas ballast II	Torr	5×10 ⁻²	5×10 ⁻²	5×10 ⁻²	5×10 ⁻²	5×10 ⁻²	5×10 ⁻²
Water vapour tolerance		Torr	40	40	25	25	40	40
Oil filling		ℓ	1.1	1.2	2.0	2.3	4.5	6.5
Inlet port		DN	25KF	25KF	25KF	25KF	40KF	40KF
Outlet port		DN	25KF	25KF	25KF	25KF	40KF	40KF
Motor power(single/3-Ph.)		kW	0.4	0.4	0.75	0.75	1.5	2.2
Rotational speed of pump	60Hz	R.P.M	1750	1750	1750	1750	1750	1750
	50Hz	R.P.M	1450	1450	1450	1450	1450	1450
Noise level(without gas ballast)		dB	50	50	52	52	56	56
Weight		kg	21	22.5	38	41	68	84

Outside Dimension

(UNIT : mm)

MODEL	A	B	C	D	E	F	G	H	I	J	K	N	S	M	L
MVP6	170	120	261	24	40	247	45	130	253	94	240	244	Ø9	210	454
MVP12	170	120	261	24	40	247	45	155	253	94	240	269	Ø9	210	479
MVP24	210	140	297	40	50	282	55	180	288	147	310	309	Ø12	234	543
MVP36	210	140	297	40	50	282	58	210	288	147	310	342	Ø12	234	576
MVP60	250	185	387	30	50	368	80	255	370	305	550	428	Ø14	281	709
MVP90	280	185	441	30	50	412	85	295	415	355	600	479	Ø14	312	791

OIL ROTARY PUMPS

MVP Series (144~324m³/h)

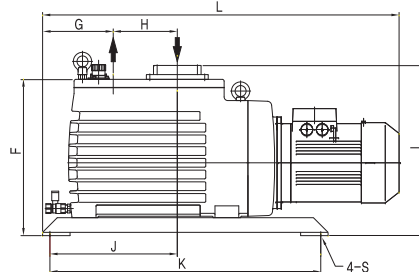
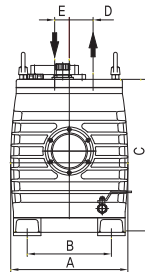

Features

- Excellent ultimate vacuum and pumping speed.
- Improved anti-suckback system to protect the pump in the event of sudden stop.
- International standard clamp and flange.
- Low noise level and low vibration level.
- Constant pressure oil circulating system.
- Convenient gas ballast control.
- Possible to attach external oil cooling device.
- Simple repairing and maintenance.

Technical Data

Description		Unit	MVP144	MVP216	MVP324
Displacement speed	60Hz	m ³ /h	144	216	324
		ℓ /min	2400	3600	5400
	50Hz	m ³ /h	120	180	270
		ℓ /min	2000	3000	4500
Ultimate pressure	With gas ballast	Torr	5×10 ⁻³	5×10 ⁻³	5×10 ⁻³
	Without gas ballast	Torr	5×10 ⁻⁴	5×10 ⁻⁴	5×10 ⁻⁴
Inlet port		mm	ISO63	ISO63	ISO63
Outlet port		mm	ISO40	ISO40	ISO40
Motor power		kW	3.7	5.5	7.5
Rotational speed of pump	60Hz	R.P.M	1750	1750	1750
	50Hz	R.P.M	1450	1450	1450
Oil filling		ℓ	11	16	17
Cooling water (less than 20°C)		ℓ /min	—	—	6
Weight		kg	172	290	358

Outside Dimension

(UNIT : mm)

MODEL	A	B	C	D	E	F	G	H	I	J	K	S	L
MVP144	320	230	501	40	65	414	193	175	465	348	740	∅14	974
MVP216	400	305	575	58	75	490	195	200	528	375	805	∅18	1101
MVP324	400	305	645	58	75	560	203	250	598	433	895	∅18	1179

OIL ROTARY PUMPS

WOVP Series

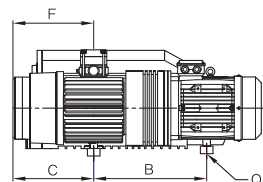
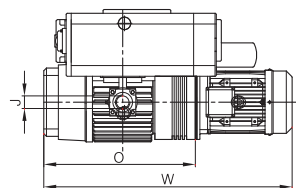
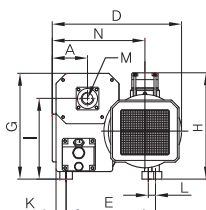

Technical Data

ITEM MODEL	Displacement Speed(ℓ /min)		Motor Power	Ultimate Pressure	Rotational Speed (R.P.M)		Noise Level(dB(A))		Oil filling	Weight
	60Hz	50Hz	kw	mbar	60Hz	50Hz	60Hz	50Hz	L	kg
WOVP-0020	200	167	0.4	2.0	1,740	1,450	59	57	0.5	20
WOVP-0030	300	249	0.75	2.0	1,740	1,450	60	58	0.5	22
WOVP-0040	400	333	0.9	2.0	3,480	2,870	62	60	0.5	20
WOVP-0060	600	500	1.2	0.5	1,740	1,450	67	64	1	47
WOVP-0130	1,300	1,080	2.2	0.5	1,740	1,450	68	65	2	66
WOVP-0200	2,000	1,670	3.0	0.5	1,740	1,450	68	65	2	75
WOVP-0320D	3,200	2,670	3.7	0.5	1,740	1,450	75	72	7	124
WOVP-0350	3,500	2,920	5.5	0.5	1,740	1,450	77	74	7	164
WOVP-0430D	4,300	3,580	5.5	0.5	1,740	1,450	77	74	7	145
WOVP-0500	5,000	4,170	7.5	0.5	1,740	1,450	77	74	7	184
WOVP-0600	6,000	5,000	8.6	0.5	1,740	1,450	78	75	7	188
WOVP-0800	9,300	7,400	15	0.5	1,160	980	78	76	19	504
WOVP-1200	13,000	10,400	18.5	0.5	1,160	980	79	77	19	703

Outside Dimension

(UNIT : mm)

MODEL	W	D	H	A	B	C	E	F	G	I	J	K	L	M	N	O	P	Q
WOVP-0020	385				217	72		72								198		
WOVP-0030	415	300	200	55	232	82	135	82	190	144	½"	25	3	G1-¼"	214	218	-	3×M8
WOVP-0040	385				217	72		72								198		
WOVP-0060	590	290	280	50	187	155	181	150	270	220	G1-¼"	15	39	G1-¼"	203	342	111	3×M8
WOVP-0130	650	410	313	50	200	145	295	145	296	246	G1-¼"	15	11	G1-¼"	295	340	-	3×M8
WOVP-0200	700				225	175	295	175								390	93	
WOVP-0320D	895	535	413	138	304	245	340	311	395	325	G2"	43	12	G1-½"	365	570	-	3×M10
WOVP-0430D	960				364	245	340	311								630	-	
WOVP-0350	1012	521	422	145	440	284	360	-	420	310	G2"	60	27	G2"	225	550	462	3×M8
WOVP-0500	1000	555	410	145	455	325	360	325	415	320	G2"	55	29	G2"	380	610	-	3×M10
WOVP-0600								-								-		
WOVP-0800	1485	860	600	240	649	500	575	500	625	485	G3"	37	37	G3"	620	340	-	3×M12
WOVP-1200	1680				757	567	575	567								1030	-	

DRY PUMPS

Carbon Vane Pumps

WVS Series

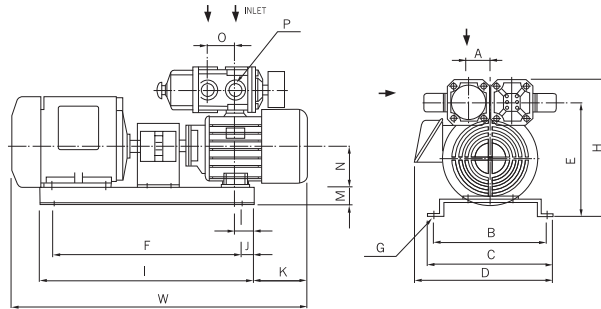
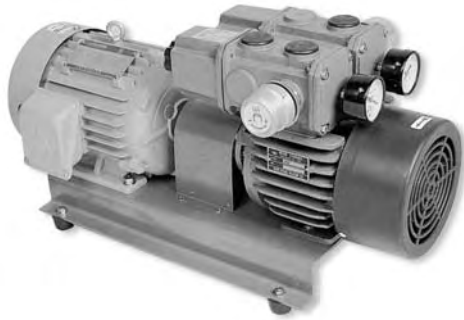

Technical Data

MODEL		WVS-3	WVS-5	WVS-6	WVS-8	WVS-9	WBS-30A	WBS-50A	WBS-60A	WBS-80A	WBS-90B
Displacement speed(l /min)	60Hz	280	480	685	1115	1350	280×2	480×2	685×2	1115×2	1350×2
	50Hz	235	405	575	935	1130	235×2	405×2	575×2		
Max. vacuum	mmHg	610	650	650	650	650	650	650	650	650	650
Normal vacuum	mmHg	450	450	450	450	450	450	450	450	450	450
Normal pressure	kgf/cm ²	0.6	0.6	0.6	0.6	0.6	0.6	0.6	0.6	0.6	0.6
Motor	Kw	0.4	0.75	1.5	1.5(6P)	2.2(6P)	0.75	1.5	2.2	4	5.5
Rotational speed of pump(R.P.M)	60Hz	1740	1740	1740	1160	1160	1740	1740	1740	1140	1160
	50Hz	1450	1450	1450	980	980	1450	1450	1450	950	
Weight	kg	24	33	44	73	97	40	56	75	115	165
Ambient	°C	0~40					0~40				

Outside Dimension

(UNIT : mm)

MODEL	W	D	H	A	B	C	E	F	G	I	J	K	L	M	N	O	P
WVS-3	500	230	255	45	200	230	205	308	4-Ø9	388	40	90	40	32	71	50	RC $\frac{3}{4}$ "
WVS-5	560	250	265	45	200	230	220	308	4-Ø9	388	40	95	40	32	80	50	RC $\frac{3}{4}$ "
WVS-6	650	270	310	45	225	255	260	380	4-Ø9	460	40	110	40	50	90	50	RC $\frac{3}{4}$ "
WVS-8	720	300	360	50	225	285	300	430	4-Ø9	510	40	130	40	60	100	70	RC1"
WVS-9	764	354	375	60	270	300	322	467	4-Ø11	567	50	118	62	60	112	80	RC1"
WBS-30A	482	90	325	270	170	90	97	28	4-Ø9	224	110	65	30	35	225	287	$\frac{3}{4}$ "
WBS-50A	559	90	325	280	170	90	112	28	4-Ø9	234	130	65	30	35	270	332	$\frac{3}{4}$ "
WBS-60A	646	505	305	202	90	90	282	28	4-Ø9	225	243	86	30	46	280	381	$\frac{3}{4}$ "
WBS-80A	695	600	350	240	115	115	315	28	4-Ø9	300	278	102	30	46	292	416	1"
WBS-90B	1070	450	390	120	350	400	340	340	4-Ø11	800	100	190	120	700	-	50	1"

DRY PUMPS

Oil Free Scroll Pumps

ISP Series



■ Principle of compression

As the orbiting scroll orbits as shown in the illustration from the No.1 position to the No.4 position, crescent shaped gas pockets are gradually reduced. At the last stage compressed gas is exhausted through the center port.

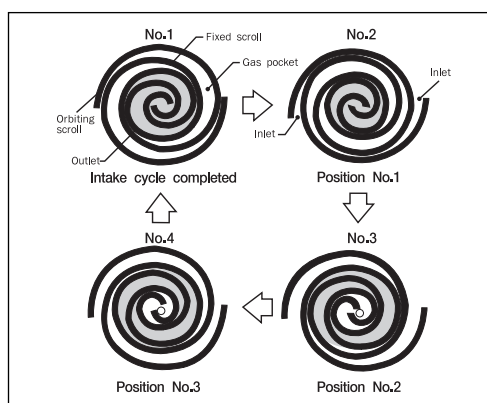

Application

- Synchrotron Facility
- Sputtering equipment, Vacuum deposition equipment, Ion plating equipment
- Gas recovery devices
- Vacuum equipment
- Leak detectors
- Device handling system
- High Vacuum pumping System
- Surface modification, Electron beam process
- Vacuum furnace, Heat treatment furnace
- Laboratory use
- Vacuum packaging machine
- Others

Technical Data

MODEL		ISP-50	ISP-90	ISP-250C	ISP-500C	ISP-1000	
Displacement speed	ℓ /min(60/50Hz)	60/50	108/90	300/250	600/500	1200/1000	
Ultimate pressure	Pa(Torr)	15{1.1×10 ⁻¹ }	≤5{3.7×10 ⁻² }	≤1.6{1.2×10 ⁻² }	≤1{7.5×10 ⁻³ }		
Motor power	Kw	0.1	0.15	0.4	0.6	1.4	
Voltage	V	single-phase	200-230V			100, 115/200, 230	-
		three-phase	-			200, 208, 230/380, 415, 460	
Noise level	dB(A)	48	52(at air flush 57)	58(at air flush 66)	60(at air flush 68)	60(at air flush 74)	
Weight	kg	single-phase	12	14	25	44	-
		three-phase	-			23	38
Leak tightness	Pa · ℓ /s	1×10 ⁻⁷ Pa m ³ /s	≤1×10 ⁻²				
Water vapor	g/day	-	5(at air flush)	25(at air flush)			
Air flush	ℓ /min	-	7(at air flush)	10(at air flush)			
Inlet connection	NW	25			40	40	
Outlet connection		16			25	40	
Cooling system		Air-Cooled					
Ambient temperature	°C	5-40				10-40	
Dimensions(L×W×H)	mm	317×155×227	308×182×225	400×252×336 (370×252×336)	443×328×372 (372×298×397)	467×390×421	

DRY PUMPS

DVSL Series



Application

- Vacuum Chuck
- Vacuum Transport
- Vacuum Forming
- Deairator
- Gas Substitution
- Vacuum Drying
- Vacuum Packing
- Cryopump Regeneration
- Leak Test
- Roughing for TMP

MODEL		DVSL-100C	DVSL-500C	DVSL-501C (Fluore rubber seal)
Displacement speed (ℓ /min)	60Hz	120	520	
	50Hz	100	430	
Ultimate pressure	Pa(Torr)	≤20(1.5×10 ⁻¹)	30(2.2×10 ⁻¹)	100(7.5×10 ⁻¹)
Motor power	Kw	0.3	1.1	
Voltage	V	Single phase 100, 115/220, 230	Three phase 200, 208, 230/380, 415, 460	
Noise level	dB(A)	59(1m, 60Hz)	64(at air flush 70)	
Weight	kg	15	36	
Water vapor	g/day	100	250	
Inlet connection	NW	25(Inside RC 3/8)		25(Inside RC 1/2)
Outlet connection		16	25	
Cooling system		Air-Cooled		
Dimensions(L×W×H)	mm	350×220×237	491×317×280	
Standard equipment		Air Flush	Air Flush, Caster, Hour counter	

★Option : Water Separator & Silencer

GVS Series



Application

- Vacuum Chuck
- Vacuum Transport
- Vacuum Forming
- Degassing
- Gas Substitution
- Vacuum Drying
- Vacuum Packing
- Leak Test

MODEL		GVS-250	GVS-500B	GVS-501B	GVS-1000
Displacement speed	ℓ /min(60/50Hz)	255/208	505/423		1046/876
Ultimate pressure	Pa(Torr)	750(5.6)	500(3.7)		
Motor power	kW	0.75	1.2		2.2
Voltage	V	Single Phase AC100(50/60Hz), AC115(60Hz)	Three Phase AC200(50/60Hz), AC220(60Hz)		Three Phase AC200(50/60Hz), AC220(60Hz)
Noise level	dB(A)	61	64		72
Weight	kg	39			65
Water vapor	g/day	250(at Air Flush)			500(at Air Flush)
Air flush	ℓ /min	10(at Air Flush)			10(at Air Flush) ※
Dimensions		W320×L570×H289	W317×L568×H289		W322×L901×H280
Inlet connection		Rc 1			
Outlet connection		Rc 1/2			
Coolong System		Air-Cooled			

★Option : Control Box, Hour Meter, Filter

DRY PUMPS

Dry Screw Vacuum Pump

WSDP Series

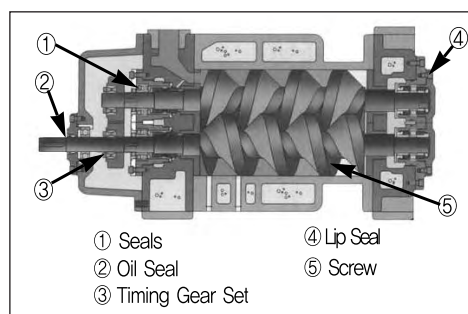

- ① Seals
- ② Oil Seal
- ③ Timing Gear Set
- ④ Lip Seal
- ⑤ Screw

Applications

Chemicals

- Organic Chemical Plants
- Petrochemical Plants
- Fine Chemical Plants
- Polymer : Polymerizations, Dryer, Extruder
- Inorganic Chemicals

Food Processing

- Oil Deodorizations
- Dryer
- Concentrations

Pharmaceutical

- Raw Material Processing
- Dryer, Refinery

Features

- PMS
- Shorter Discharge Time / High Performance
- Maximum Resistance to Heat and Corrosion
- Interchangeable with Mechanical Seal and Lip Seal
- ISO Standard motor
- High Stiffness Gear with High Accuracy
- Excellent durability
- Low Operation cost / Low maintenance cost

Technical Data

Description		MODEL	Units	WSDP-150	WSDP-300	WSDP-400	WSDP-800
Nominal capacity (50/60Hz)			M ³ /Hr	120/150	270/330	360/400	720/800
Ultimate Pressure (50/60Hz)			Torr	0.5/0.3	0.1/0.05	0.1/0.03	0.05/0.01
Power			Kw	7.5	11	15	22
Rotational Speed (50/60Hz)			rpm	2900/3500			
Port Size	Suction		mm	40	50	65	100
	Discharge		mm	40	40	50	80
Gear Oil			liters	1.3	1.6	2	7
Cooling Water			l/min	2	3.5	7	28
Weight			kg	230	350	430	1150

Technical Data

Description		MODEL	Units	WVDP-100	WVDP-200	WVDP-400	WVDP-800	WVDP-1500	WVDP-3000
Nominal capacity	50Hz		M ³ /Hr	80	160	360	720	1200	2400
	60Hz			100	200	400	800	1500	3000
Ultimate Pressure	50Hz		Torr	0.03				0.01	
	60Hz			0.007				0.005	
Power			Kw	5.5	7.5	11	19	30	55
Rotational Speed (50/60Hz)			rpm	2900 / 3500					
Port Size	Suction		mm	40	50	65	100	125	150
	Discharge			40	40	50	65	80	100
Gear Oil			liters	1.3	1.6	2	4	7	9
Cooling Water			l/min	2	3.5	7	10	28	36
Weight			kg	230	350	430	630	1150	1450

★Option : Cooler, Separator, Temperature Switch, N2 Purging Line, Control Panel.

DRY PUMPS

Dry Screw Vacuum Pump

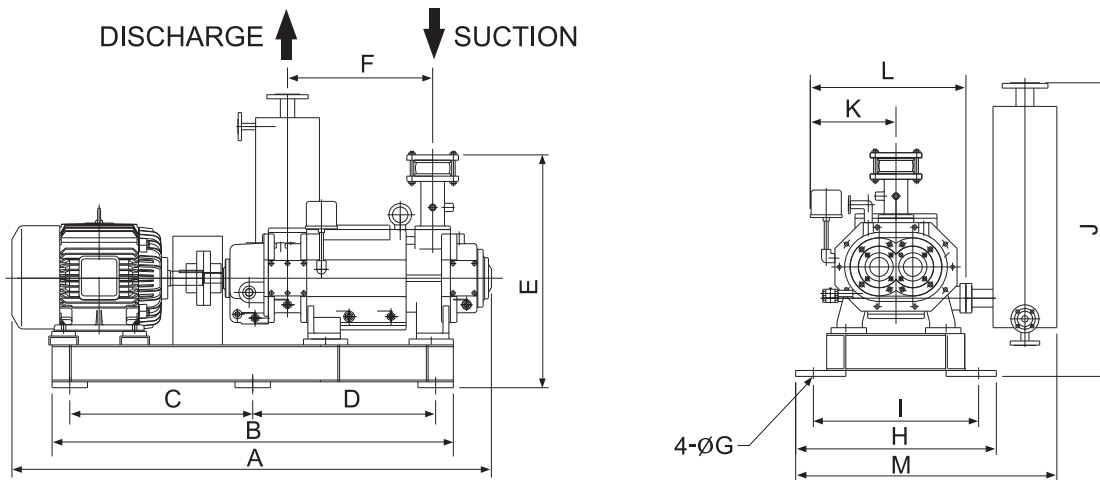

Dimension

MODEL	A	B	C	D	E	F	G	H	J	L	Port Size(mm)	
											SUC	DIS
WSDP-150	1350	1050	465	465	710	359	Ø22	490	863	460	40	40
WSDP-300	1520	1300	590	590	766	443	Ø22	658	895	492	50	40
WSDP-400	1573	1360	620	620	785	492	Ø22	668	995	512	65	50
WSDP-800	1750	1550	715	715	873	556	Ø22	750	1275	643	100	65

★These Dimensions are subject to change without notice for quality improvement

Accessories

1. Accessories before WSDP
 - Precondenser, Butterfly Valves for Vacuum Regulation
 - Suction Cartridge Filter, Vacuum breaking Valves, etc
2. Accessories on WSDP
 - Suction Check Valve, Suction Flange, Sealing Gas Connection
 - Cooling Gas Connection, Control Box
3. Accessories after WSDP
 - After Condenser, Discharge Silencer (Water Cooled)
 - Discharge Separator, Gas Cooler

DRY PUMPS

Semiconductor Dry Pump Series

DD105 Series



Plan

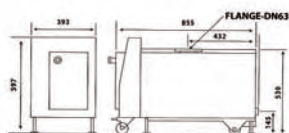

DD105

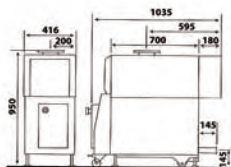

DD1205

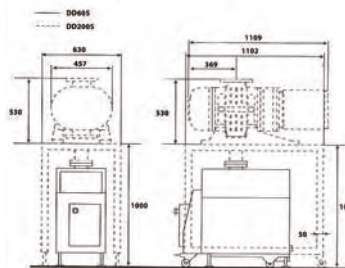

DD605/DD2005

Technical Data

Description	Units	DD105	DD605	DD1005	DD1205	DD1805	DD2005
Theoretical Displacement	m ³ /hr	120	606	1008	1200	2016	2460
Nominal Pumping speed	m ³ /hr	105	480	714	900	1115	2020
Ultimate pressure with full CVD purge	Torr	$\leq 5.0 \times 10^{-3}$		$\leq 6.0 \times 10^{-4}$			$\leq 5.0 \times 10^{-4}$
Maximum intake pressure in continuous operation	Torr	760	20		10		10
Maximum exhaust pressure		1.5					
Nitrogen supply pressure	bar	4 to 8					
Internal purge-gas pressure		3					
Nitrogen consumption - ETCH		12					
Nitrogen consumption - CVD	slm	50					
Exhaust flush purge (optional)		100					
Exhaust hot N2 purge (optional)	°C	≤ 180					
Nitrogen connection	inch	$\frac{3}{8}$ " NPTF with $\frac{1}{4}$ " NPT Tube Connector					
Cooling water flow	L/min	1.8 to 2.8					
Cooling water temp	°C	15 to 30					
Cooling water pressure With $\Delta P \geq 1$ bar	bar	3.5 to 9					
Cooling water connection	inch	$\frac{1}{2}$ " NPTF with $\frac{3}{8}$ " Tube Connector					
Intake port		DN 63 ISO-K			DN 100 ISO-K		DN 160 ISO-K
Exhaust port		DN 40 KF					
Dimensions - WxLxH		400x987x596	400x987x840		400x1153x1065		720x1150x1150
Weight	Kg	278	435		578		965
Maximum ambient temperature	°C	40					
Minimum ambient temperature	°C	10					
Typical power consumption	Kw	4.0	5.0		6.0		9.0
Typical Motor power	Kw	5.0	7.4		9.0		15.9
Supply Voltage - Multi-Voltage Motor	V/Ø/Hz	200-208-230 / 460-480 V ($\pm 10\%$), 3Ø, 60Hz 200-208 / 380-415V ($\pm 5\%$), 3Ø, 50Hz					
Short Circuit Interrupt Capacity (SCIC)	kA	100					
PEPE oil quantity in gear box †	Liters	1.1 †	1.1 + 1 for blower †		1.14 + 2 for blower †		1.1 + 5 for blowers †
Ferquency Converter		NO	NO	YES	NO	YES	NO

† The DuraDry models with the optional external heat exchanger require an additional 0.3 liters of PFPE oil.

DRY PUMPS

Semiconductor Dry Pump Series

DD255 Series



Plan

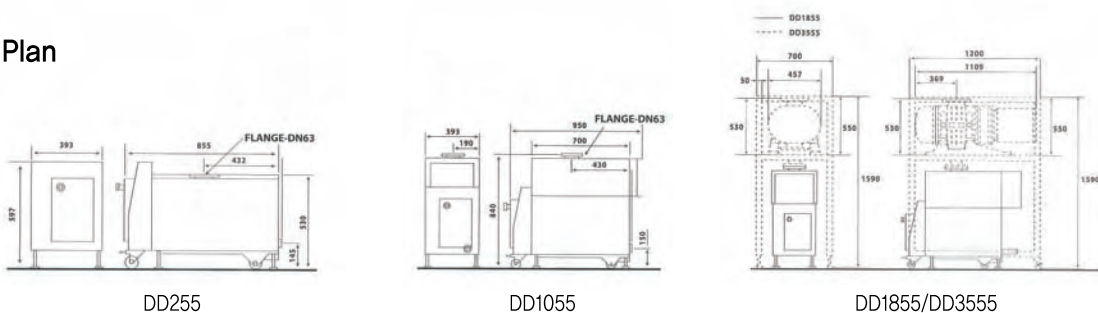

Technical Data

Description	Units	DD255	DD1055	DD1855	DD2055	DD3055	DD3555
Theoretical Displacement	m ³ /hr	225	606	1613	2873	2460	3694
Nominal Pumping speed	m ³ /hr	200	540	1210	1853	2020	3660
Ultimate pressure	Torr	≤5.0×10 ⁻³		≤5.0×10 ⁻⁴			
Maximum exhaust pressure		1.5					
Nitrogen supply pressure	bar	4 to 8					
Internal purge-gas pressure		3					
Nitrogen consumption – ETCH		12					
Nitrogen consumption – CVD	slm	50					
Exhaust flush purge (optional)		100					
Exhaust hot N ₂ purge (optional)	°C	≤180					
Nitrogen connection	inch	3/8" NPTF with 1/2" NPT Tube Connector					
Cooling water flow	L/min	1.8 to 2.8					
Cooling water temp	°C	15 to 30					
Cooling water pressure With ΔP≥1 bar	bar	3.5 to 9					
Cooling water connection	inch	1/2" NPTF with 3/8" Tube Connector					
Intake port		DN 63 ISO-K		DN 100 ISO-K	DN 160 ISO-K		
Exhaust port	mm	DN 40 KF					
Dimensions – WxLxH		400×987×596	400×987×840	400×1153×1065	700×1310×1130	700×1310×1490	700×1310×1600
Weight	Kg	278	435	578	714	871	1014
Maximum ambient temperature	°C	40					
Minimum ambient temperature	°C	10					
Typical power consumption	Kw	4.0	5.0	6.0	7.0	8.0	9.0
Typical Motor power	Kw	5.0	7.4	9.0	11.9	14.3	15.9
Supply Voltage – Multi-Voltage Motor	V/∅/Hz	200–208–230 / 460–480 V (±10%), 3∅, 60Hz 200–208 / 380–415V (±5%), 3∅, 50Hz					
Short Circuit Interrupt Capacity (SCIC)	kA	100					
PEPE oil quantity in gear box †	Liters	1.1 †	1.4 + 1 for blowers †	1.4 + 2 for blowers †	1.1 + 3 for blowers †	1.1 + 4 for blowers †	1.1 + 5 for blowers †
Ferquency Converter		NO	YES	YES	YES	YES	YES

† The DuraDry models with the optional external heat exchanger require an additional 0.3 liters of PFPE oil.

WATER RING PUMPS

Water Ring Pumps

WWVP Series



〈Single Stage Pump WWVP-1〉

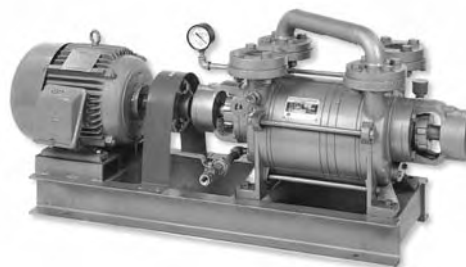

〈Two Stage Pump WWVP-2〉

Single Stage Water Ring Pumps

*Ultimate Pressure(at 15°C)

MODEL	Displacement Speed (ℓ /min)	*Ultimate Pressure Torr(pa)	Rotational Speed (R.P.M)	Motor Power (kw)	Cooling Water Capacity (ℓ /min)	Inlet Port (mm)	Outlet Port (mm)	Weight (kg)
WWVP-1-100	1000	50(6.7×10 ³)	1750	2.2	7	40A	40A	70
WWVP-1-170	1700	50(6.7×10 ³)	1750	3.7	9	40A	40A	86
WWVP-1-300	3000	50(6.7×10 ³)	1750	5.5	10	50A	50A	130
WWVP-1-400	4000	50(6.7×10 ³)	1750	7.5	14	50A	50A	137
WWVP-1-500	5000	50(6.7×10 ³)	1750	11	20	80A	80A	187
WWVP-1-700	7000	50(6.7×10 ³)	1750	15	30	80A	80A	215
WWVP-1-900	9000	50(6.7×10 ³)	1750	19	34	80A	80A	223
WWVP-1-1100	11000	50(6.7×10 ³)	1750	22	38	125A	125A	348
WWVP-1-1500	15000	50(6.7×10 ³)	1750	30	42	125A	125A	390
WWVP-1-1800	18000	50(6.7×10 ³)	1150	37(6P)	60	150A	150A	510
WWVP-2-2000	20000	50(6.7×10 ³)	1150	45(6P)	65	150A	150A	675
WWVP-1-2500	25000	50(6.7×10 ³)	880	55(8P)	85	200A	200A	1085
WWVP-1-3400	34000	50(6.7×10 ³)	1150	75(6P)	95	200A	200A	1015

Two Stage Water Ring Pumps

*Ultimate Pressure(at 15°C)

MODEL	Displacement Speed (ℓ /min)	*Ultimate Pressure Torr(pa)	Rotational Speed (R.P.M)	Motor Power (kw)	Cooling Water Capacity (ℓ /min)	Inlet Port (mm)	Outlet Port (mm)	Weight (kg)
WWVP-2-045	450	17(2.3×10 ³)	3400	1.5	6	25A	25A	50
WWVP-2-085	850	17(2.3×10 ³)	1750	2.2	7	40A	40A	87
WWVP-2-150	1500	17(2.3×10 ³)	1750	3.7	9	40A	40A	107
WWVP-2-250	2500	17(2.3×10 ³)	1750	5.5	10	40A	40A	132
WWVP-2-300	3000	17(2.3×10 ³)	1750	7.5	14	40A	40A	143
WWVP-2-400	4000	17(2.3×10 ³)	1750	11	20	50A	50A	195
WWVP-2-550	5500	17(2.3×10 ³)	1750	15	30	50A	50A	213
WWVP-2-700	7000	17(2.3×10 ³)	1750	19	34	50A	50A	255
WWVP-2-800	8000	17(2.3×10 ³)	1750	22	38	80A	80A	390
WWVP-2-1000	10000	17(2.3×10 ³)	1750	30	42	80A	80A	570
WWVP-2-1200	12000	17(2.3×10 ³)	1150	37(6P)	60	80A	80A	685
WWVP-2-1300	13000	17(2.3×10 ³)	1150	45(6P)	65	80A	80A	720
WWVP-2-2000	20000	17(2.3×10 ³)	880	55(8P)	85	100A	100A	1150
WWVP-2-2800	28000	17(2.3×10 ³)	1150	75(6P)	95	100A	100A	1078

WATER RING PUMPS

Direct Type Pump

WWVP-D Series

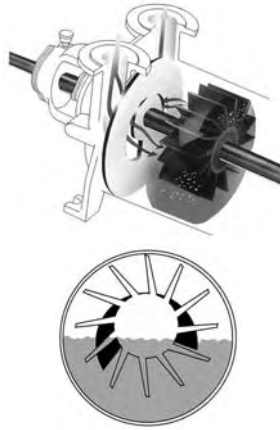

Liquid level when pump is at rest.

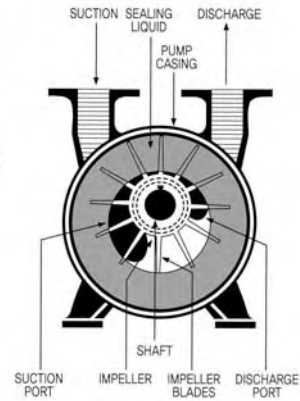

Operating Principle of Liquid Ring Vacuum Pump

Technical Data

*Ultimate Pressure(at 15°C)

MODEL	Displacement Speed (ℓ /min)	*Ultimate Pressure Torr(pa)	Rotational Speed (R.P.M)	Motor Power (kw)	Cooling Water Capacity (ℓ /min)	Inlet Port (mm)	Outlet Port (mm)	Weight (kg)
WWVP-D-100	1000	50(6.7×10 ³)	1750	2.2(4P)	7	40A	40A	65
WWVP-D-170	1700	50(6.7×10 ³)	1750	3.7(4P)	9	40A	40A	75

Ejector

Gas(Air) ejector is operated with gases or compressor. The operating principles of a Gas(Air) ejector is that the pressure energy in the motive gas(air) is converted into velocity energy in the nozzle, and this high velocity jet of gas(air) entrains the vapor of gas being pumped.

※ Especially, Air ejector is installed at suction side of watering vacuum pump, it can prevent cavitation of vacuum pump at max. vacuum deg. and produce max. vacuum deg. up to 20 Torr.

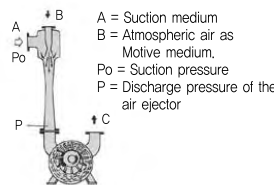

INSTALLATION FOR VACUUM PUMP

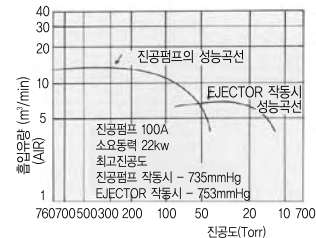

AIR EJECTOR

Steam under pressure discharge at high velocity through a nozzle and entrains the suction liquid or slurry.

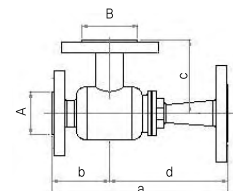

Connection, Dimension & Approx Weight

ITEM / TYPE		DSE20	DSE25	DSE40	DSE50	DSE65	DSE80
Connection	A	15A	20A	25A	32A	40A	50A
	B	20A	25A	40A	50A	65A	80A
	C	20A	25A	40A	50A	65A	80A
Dimension	a	130	190	235	285	380	460
	b	50	60	70	75	95	110
	d	70	80	85	100	120	125
Approx Weight	kg	3	4	8	12	17	26

BOOSTER PUMPS

Booster Pumps

GMa / Gmb



Direction of flow

- GMa/b=vertical or GLa/b=horizontal
- Blower up to size 16.13 HV alternatively vertical to the bottom or horizontal to the right.
- Blower up to size Gmb 17.15 HV vertical to the bottom.

Drive

Direct coupling with motor or via spur gear, con-verter operation, narrow v-belt drive restricted to the smaller pressure differentials.

Fields of application

- Conveying of air and neutral gases.
- Vacuum from 10^{-2} mbar to approx. 200 mbar for HV-blowers
available in 19 sizes for theoretical nominal suction volume flow from 180 to 97,000 m³/h
- The max. admissible differential pressure depends on the thermal load.

Technical Data

Size:	Theoretical suction volume at		Mech. max. adm. differential pressure	Oil filling quantities for		Motor rating at 50 Hz	Speed	System voltage	Total weight Stage + drive
	50 Hz	60 Hz		GMa/b	GLa/b				
	[m ³ /h]	[m ³ /h]	[mbar]	[liter]	[liter]	[kW]	[1/min]	[V]	[kG]
10.0 HV	180	215	130	0,9	0,7	0,75	3000	230/400	80
10.1 HV	240	295	140	0,9	0,7	1,1	3000	230/400	90
10.2 HV	365	440	130	0,9	0,7	1,5	3000	230/400	105
11.3 HV	500	600	140	1,1	0,8	2,2	3000	230/400	125
11.4 HV	730	880	130	1,1	0,8	3	3000	400/690	170
12.5 HV	1000	1200	130	1,5	1,1	4	3000	400/690	225
12.6 HV	1400	1700	130	1,5	1,1	5,5	3000	400/690	275
13.17 HV	2010	2420	110	2,5	2,1	7,5	3000	400/690	330
13.8 HV	2840	3420	100	2,5	2,1	11	3000	400/690	445
14.9 HV	3850	4700	80	7	3,5	11	3000	400/690	545
15.10 HV	5500	6650	80	12	5,4	15	3000	400/690	680
15.11 HV	7350	8950	80	12	5,4	18,5	3000	400/690	960
16.12 HV	5330	6400	110	11	7,6	18,5	1500	400/690	1310
16.113 HV	8000	9600	75	11	7,6	18,5	1500	400/690	1460
16.13 HV	9535	11440	75	11	7,6	22	1500	400/690	1500
17.15 HV	15685	18825	60	18,5	-	30	1470	400/690	2020

BOOSTER PUMPS

Booster Pumps

WSBP Series

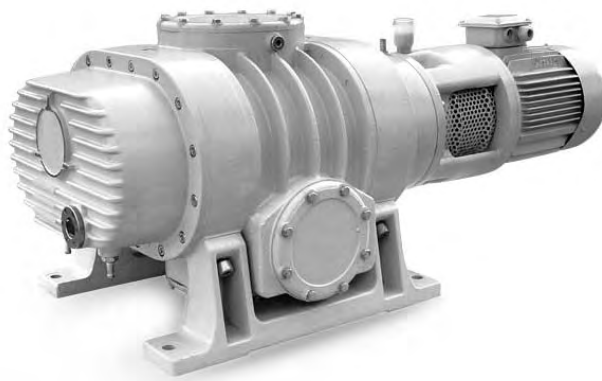

Features

- No mechanical friction and noise, which to avoid the high-frequency transmission of power
- Compared with the rigid coupling, Magnetic drive is low noise, crash, and start running smoothly
- Magnetic drive can effectively protect the motor from electrical overload when Booster pump starting
- The sealing structure in inner structure keeps little distance with outer magnet, so it can protect the pump from friction and lubricant contamination, that the pump will works long-term without any leakage
- The structure without oil seal will not affect the ultimate pressure. The pump does not require lubrication, which can clean up the environment.

Technical Data

Description		Unit	WSBP30C	WSBP70C	WSBP 150C	WSBP 300C	WSBP 600C	WSBP 1200C	WSBP 1800C	WSBP 2500C
Displacement speed(60/50Hz)		M ³ / Hr	120/100	300/250	600/500	1200/1000	2400/2000	4800/4000	7200/6000	10800/9000
Ultimate pressure		Pa(Torr)	3×10 ⁻² (2×10 ⁻⁴)							
Permissible ambient temperatures		°C	5~40							
Motor Power(60/50Hz)		Kw	0.75	1.1	2.2	3.7	7.5	11	15	18.5
Rotation speed(60/50Hz)		rpm	3500/2825	3500/2825	3500/2840	3500/2890	3500/2890	3500/2890	3500/2890	3500/2890
Oil Filing for Gear box		ℓ	0.8	0.8	2.8	2.8	7.5	7.5	10.5	10.5
Port Size	Inlet Port	mm	50	80	100	150	200	250	250	250
	Outlet Port	mm	40	50	100	150	200	200	320	320
Cooling Water Supply		ℓ /min	-	-	-	-	8	10	12	12
Weight(with motor)		kg	80	80	180	245	575	800	1150	1400

★WSBP30C – Atmospheric & Magnetic drive, WSBP 70C ~ 2500 – Decompression & Magnetic drive

DIFFUSION PUMPS

Diffusion Pumps

WSD Series

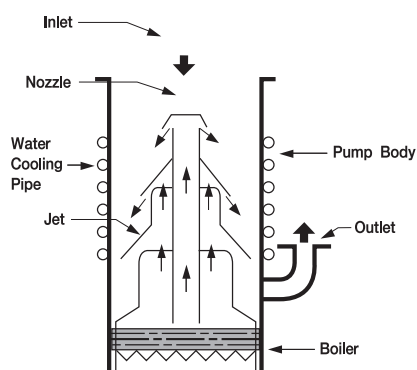

Structure & Working Principle

- Oil Steam ejected toward lower direction and gas molecule are captured in the jet vapour stream and then discharging out after condensation.
- It consists of pump body, diffusion pump oil, boiler heater and jet stack assembly. The water cooling pipe winds around the pump body in order to put condensed vaporize steam back to the liquids
- Install outlet for the purpose of discharging out condensed gas molecules from lower wall of pump body to the backing pump
- Pump body usually has jar and cylinder types and are stainless steel material mostly. Attain to a higher vacuum is to install a cold trap at inlet side.



Technical Data

Model		Unit	WSD-3Z	WSD-4Z	WSD-6Z	WSD-8Z	WSD-10Z	WSD-14Z	WSD-22Z	WSD-28Z	
Pumping Speed	Without Baffle	ℓ /sec	360	570	1200	1950	3000	5500	13000	18500	
	With Baffle		220	310	600	1100	1650	3030	7200	10200	
Ultimate Pressure with Baffle		Torr	1.0×10 ⁻⁷						1.0×10 ⁻⁷ (1.3×10 ⁻⁵)		
Heater Power			220V×1φ, 450W	220V×1φ, 700W	220V×1φ, 1Kw	220V×1φ, 1.5Kw	220V×1φ, 1.8Kw	220V×1φ, 4.5Kw	220V×1φ, 9Kw	220V×3φ, 15Kw	
Warm up-Time		min	20	20	20	25	25	30	35	40	
Oil Filling		cc	100	150	340	500	820	1600	5000	9000	
Cooling			Water Cooling								
Oil Backstream		mg/orf.min	7.5×10 ⁻⁴			2.0×10 ⁻⁴					
Cooling Water Flow		ℓ /min	1	1.5	3	4	5	7	11	15	
Inlet Size			NW80	VG100	VG150	VG200	VG250	VG350	VG550	VG700	
Outlet Size			NW25	VG25	VG50	VG50	VG80	VG100	ISO160	VG200	
Weight		kg	6	10	20	30	41	120	180	270	

★Option : Oil Level Viewing Port, Diffusion Oil, Bimetal, Quick Cooling unit

BOOSTER PUMP SYSTEMS

Booster Pumping System

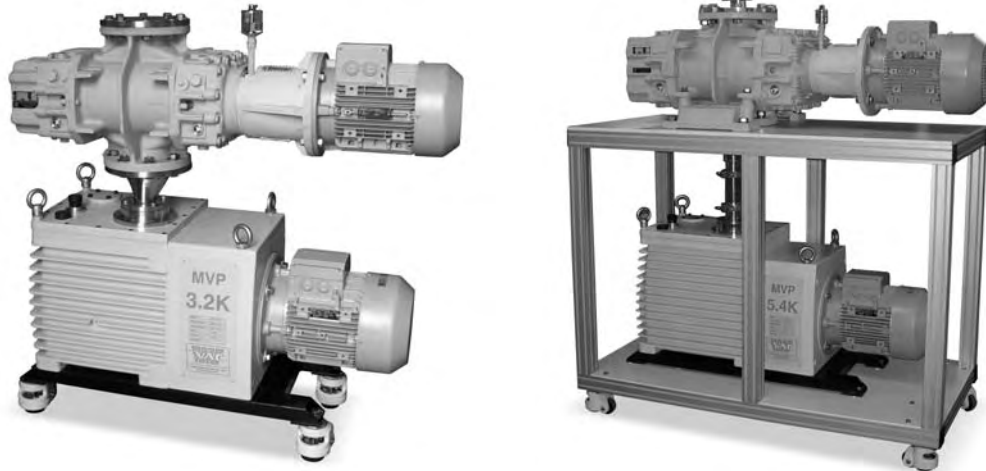

Feature

- High Capacity system which is assembled by Compact Structure
- Easy installation and transportation
- Convenient operation function unit

WBSD(Dry Type) Series

MODEL		WBSD-5K	WBSD-10K	WBSD-20K	WBSD-40K	WBSD-80K	WBSD-160K
Booster Pump (1차)		GMa10.1HV	GMa11.3HV	GMa12.5HV	GMa13.7HV	GMa14.9HV	GMa16.f13HV
Booster Pump (2차)		-	-	-	-	GMa13.7HV	GMa14.9HV
Backing Pump		DVSL 500	WDP 200	WDP 450	WDP 850		
Pumping Speed (m ³ /h)	60Hz	215	600	1200	2420	4700	9600
	50Hz	180	500	1000	2010	3850	8000
Ultimate Pressure		5.3×10 ⁻⁴ Torr (7.2×10 ⁻² Pa)					
Package Power (Kw)		1.9	13.2	19	29.5	40.5	59
Inlet Port (A)		80	100	100	150	200	300
Outlet Port (A)		NW40	40	50	80	80	80
Weight (Kg)		132	465	585	890	1325	2185

WBSO(Oil Type) Series

MODEL		WBSO-5K	WBSO-10K	WBSO-20K	WBSO-40K	WBSO-80K	WBSO-160K
Booster Pump (1차)		GMa10.1HV	GMa11.3HV	GMa12.5HV	GMa13.7HV	GMa14.9HV	GMa16.f13HV
Booster Pump (2차)		-	-	-	-	GMa13.7HV	GMa14.9HV
Backing Pump		MVP-36	MVP144	MVP216	MVP324	MVP540	
Pumping Speed (m ³ /h)	60Hz	215	600	1200	2420	4700	9600
	50Hz	180	500	1000	2010	3850	8000
Ultimate Pressure		1×10 ⁻⁴ Torr (1.3×10 ⁻² Pa)					
Package Power (Kw)		1.85	5.9	14	29.5	40.5	51.5
Inlet Port (A)		80	100	100	150	200	300
Outlet Port (A)		NW40	ISO40	ISO40	ISO100	ISO100	ISO100

DIFFUSION PUMP SYSTEMS

Diffusion Pump System

WSD S – Series



Feature

- Easy transportation and movement
- Multiple use
- Easy preservation
- Available upon request
- Available in manual & automatic

Application

- Laboratory use
- Exhausting for a minor vacuum
- Ultra vacuum use

Technical Data

MODEL		WSD-4S	WSD-6S	WSD-8S	WSD-10S
Ultimate pressure	Torr	10 ⁻⁶			
Oil rotary pump	ℓ /min	200	300	600	1000
Oil diffusion pump	ℓ /sec	570	1200	1950	3000
High vacuum valve	Inch	4	6	8	10
Low vacuum valve	Inch	1	1	2	4
Foreline valve	Inch	1	1	2	4
Cold trap	Inch	4	6	8	10
Water baffle	Inch	4	6	8	10
Power(220V, 3P, 60Hz)	Kw	1.5	3	5	7.5
Cooling water(20°C1kg/cm ²)	ℓ /min	3	5	8	10
Operation method	Type	Manual & Pneumatic			
Option		Vacuum Gauge, chamber, Valve, etc			

PLC Leak Test Machine



Technical Data

- Vacuum Chamber : 2 chamber 1050(W)×850(H)×200(D)
- Vacuum Pump : Booster + Oil Rotary Pump
- Vacuum Pressure : 0.001 Torr
- N₂ Charge : 40 kg/cm²
- Leak Rate as He Gas : 5×10^{-9} pa.m³/sec
- Cycle time : 70 sec / 2 chamber
- Construction Material for the chamber : SUS304
- He Recovery : 90%
- Leak Detector : Heliot 710
- Control : Full Auto, PLC, Touch Panel
- He Tank : 500ℓ , Max pressure : 50 kg/cm²
- Power Supply : 380V 50/60Hz three phase
- Consumption : about 25Kw

SYSTEM LAYOUT

Exhaust Vacuum System

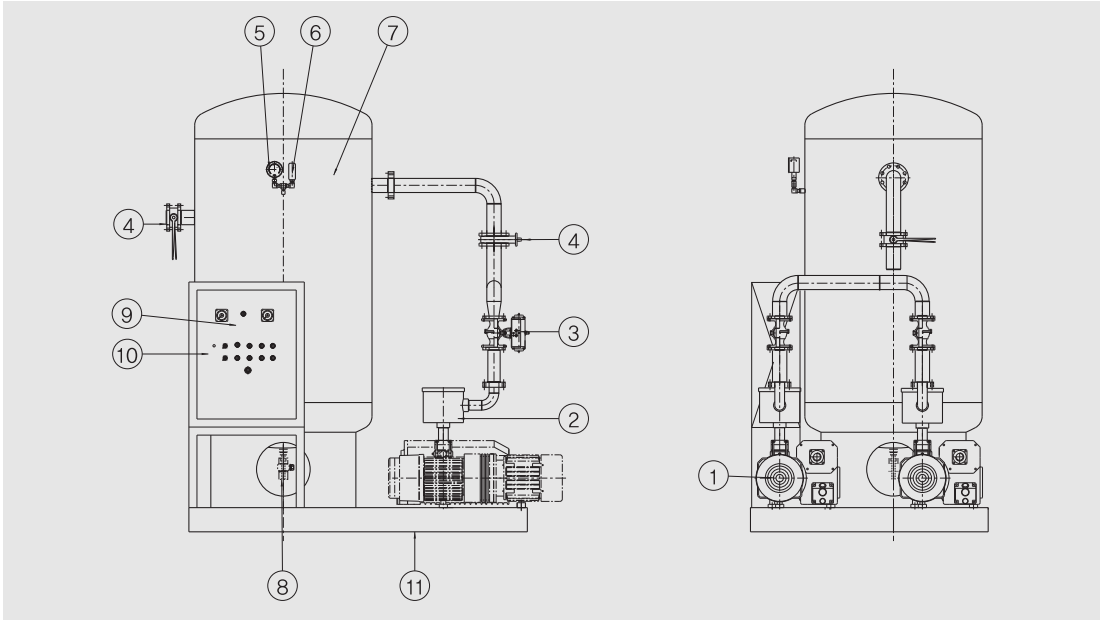

Description

- ❶ OIL ROTARY VACUUM PUMP
- ❷ INLET FILTER
- ❸ PNEUMATIC BALL VALVE
- ❹ BUTERFLY VALVE
- ❺ VACUUM GAUGE
- ❻ PRESSURE TRANSMITTER

- ❼ RESEVER TANK
- ❽ DRAIN BALL VALVE
- ❾ DIGITAL INDICATOR
- ❿ CONTROL BOX
- ⓫ FRAME

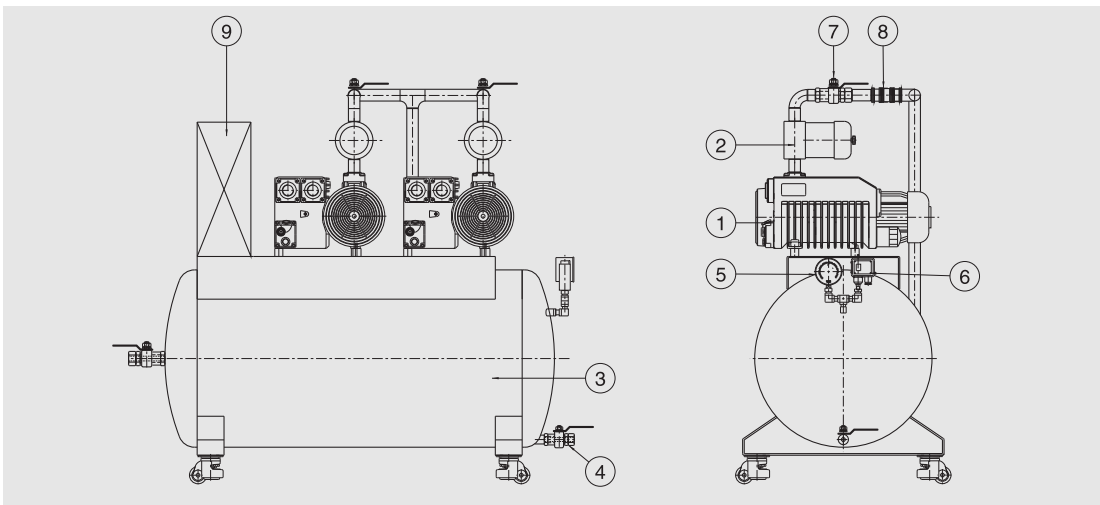

Description

- ❶ OIL ROTARY VACUUM PUMP
- ❷ INLET FILTER
- ❸ RECEVER TANK
- ❹ DRAIN BALL VALVE
- ❺ VACUUM GAUGE

- ❻ VACUUM SWITCH
- ❼ BALL VALVE
- ❽ BELLOWS TUBE
- ❾ CONTROL BOX

SYSTEM LAYOUT

Watering Vacuum System

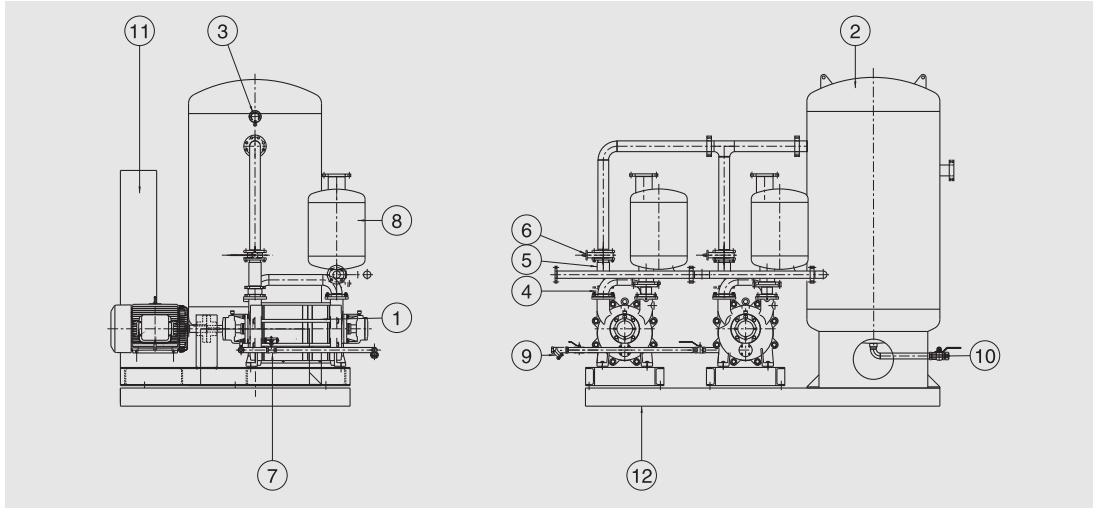

Description

- | | |
|--------------------------|------------------------|
| ① WATER RING VACUUM PUMP | ⑦ PNEUMATIC BALL VALVE |
| ② RECEIVER TANK | ⑧ SEPARATE TANK |
| ③ VACUUM GAUGE | ⑨ STRAINER |
| ④ CHECK VALVE | ⑩ CONTROL BOX |
| ⑤ FLEXIBLE | ⑪ FRAME |
| ⑥ BUTERFLY VALVE | |

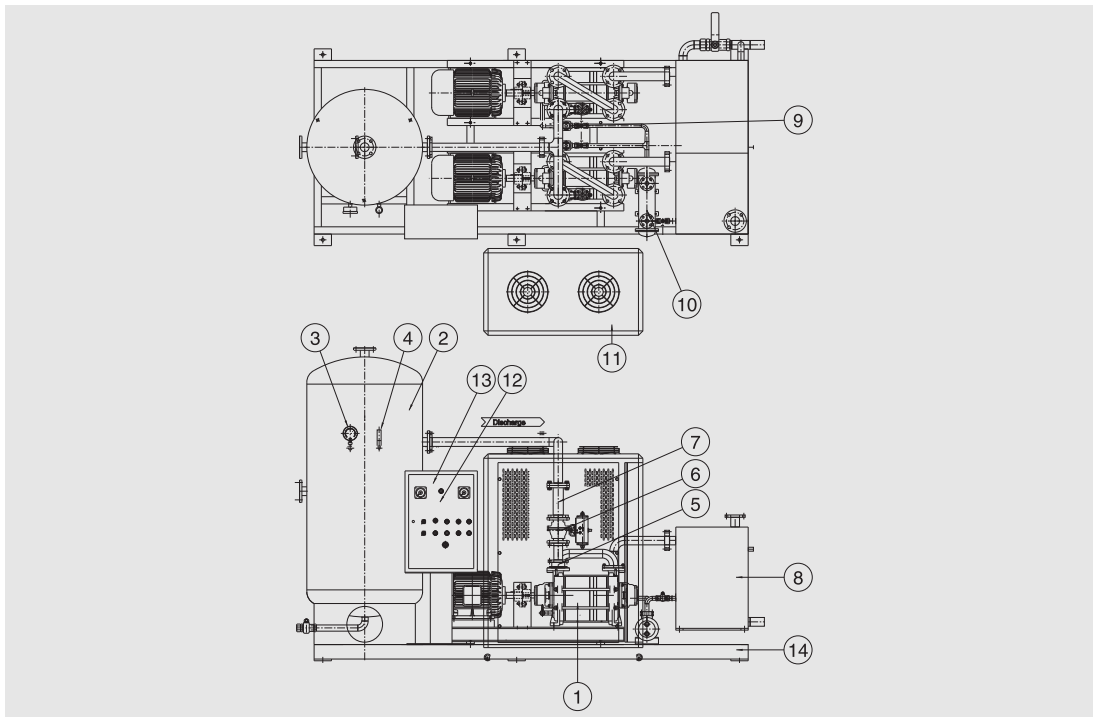

Description

- | | |
|--------------------------|---------------------|
| ① WATER RING VACUUM PUMP | ⑧ SEPARATE TANK |
| ② RECEIVER TANK | ⑨ SOLENOID VALVE |
| ③ VACUUM GAUGE | ⑩ HEAT EXCHANGER |
| ④ PRESSURE TRANSMITTER | ⑪ CHILLER |
| ⑤ CHECK VALVE | ⑫ DIGITAL INDICATOR |
| ⑥ PNEUMATIC BALL VALVE | ⑬ CONTROL BOX |
| ⑦ FLEXIBLE | ⑭ FRAME |

SYSTEM LAYOUT

Diffusion Pumping System

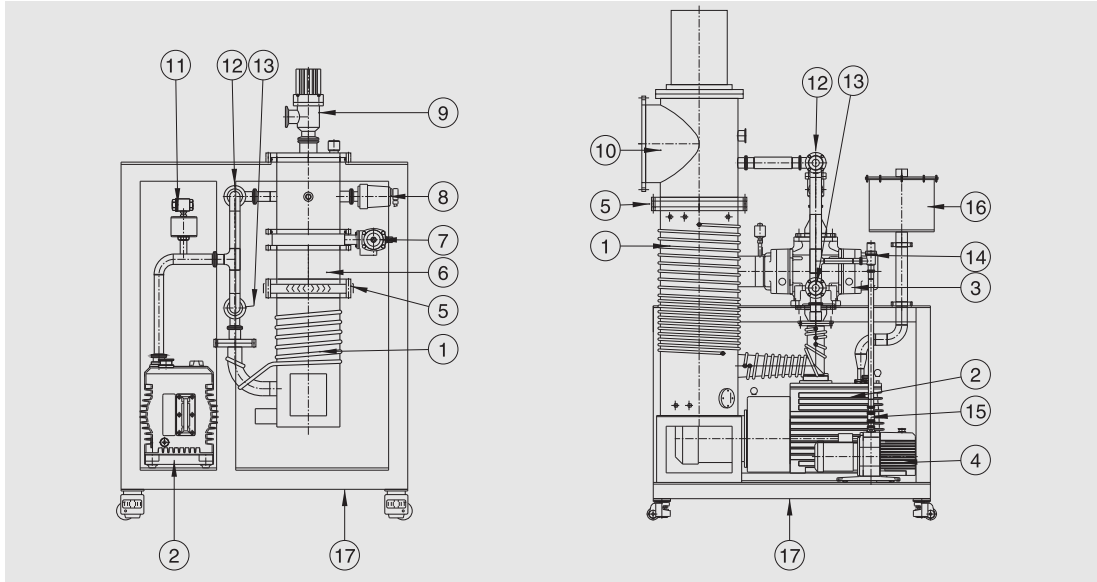

Description

- | | |
|--------------------------|----------------------|
| ① DIFFUSION VACUUM PUMP | ⑩ MAIN VALVE |
| ② OIL ROTARY VACUUM PUMP | ⑪ LEAK VALVE |
| ③ BOOSTER VACUUM PUMP | ⑫ ROUGHING VALVE |
| ④ HOLDING PUMP | ⑬ FORLINE VALVE |
| ⑤ WATER BAFFLE | ⑭ HOLDING LINE VALVE |
| ⑥ SPACE CHAMBER | ⑮ BELLOWS TUBE |
| ⑦ BUTTERFLY VALVE | ⑯ OIL MIST TRAP |
| ⑧ GAUGE SENSOR | ⑰ FRAME |
| ⑨ MAIN VALVE | |

Booster Pumping System

Air Conditioner Vacuum System

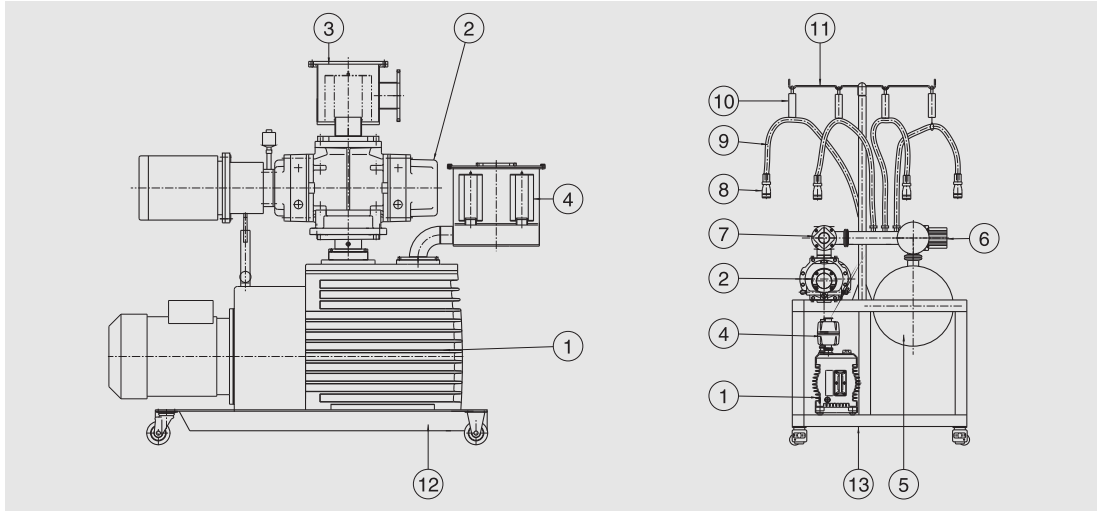

Description

- | | |
|--------------------------|-------------------|
| ① OIL ROTARY VACUUM PUMP | ⑧ COUPLER |
| ② BOOSTER VACUUM PUMP | ⑨ VACUUM HOSE |
| ③ INLET FILTER | ⑩ SPRING BALANCER |
| ④ OIL MIST TRAP | ⑪ HANGER |
| ⑤ RECEIVER TANK | ⑫ CARRIER |
| ⑥ VACUUM VALVE | ⑬ FRAME |
| ⑦ VACUUM VALVE | |

SYSTEM LAYOUT

Exhaust Vacuum System

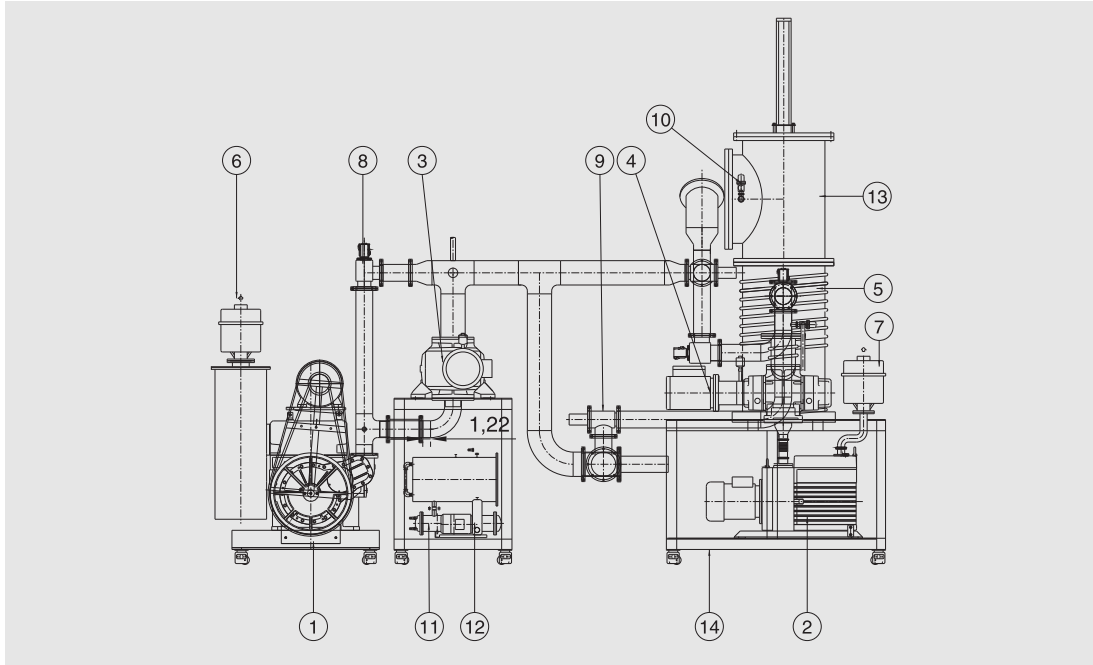

Description

- | | |
|--------------------------|-------------------------|
| ① OIL ROTARY VACUUM PUMP | ⑧ PNEUMATIC ANGLE VALVE |
| ② OIL ROTARY VACUUM PUMP | ⑨ PNEUMATIC ANGLE VALVE |
| ③ BOOSTER VACUUM PUMP | ⑩ VACUUM TRANSMITTER |
| ④ BOOSTER VACUUM PUMP | ⑪ HEAT EXCHANGER |
| ⑤ DIFFUSION VACUUM PUMP | ⑫ WATER ROTATION PUMP |
| ⑥ OIL MIST TRAP | ⑬ PNEUMATIC ANGLE VALVE |
| ⑦ OIL MIST TRAP | ⑭ FRAME |

Vacuum & Leak Test System

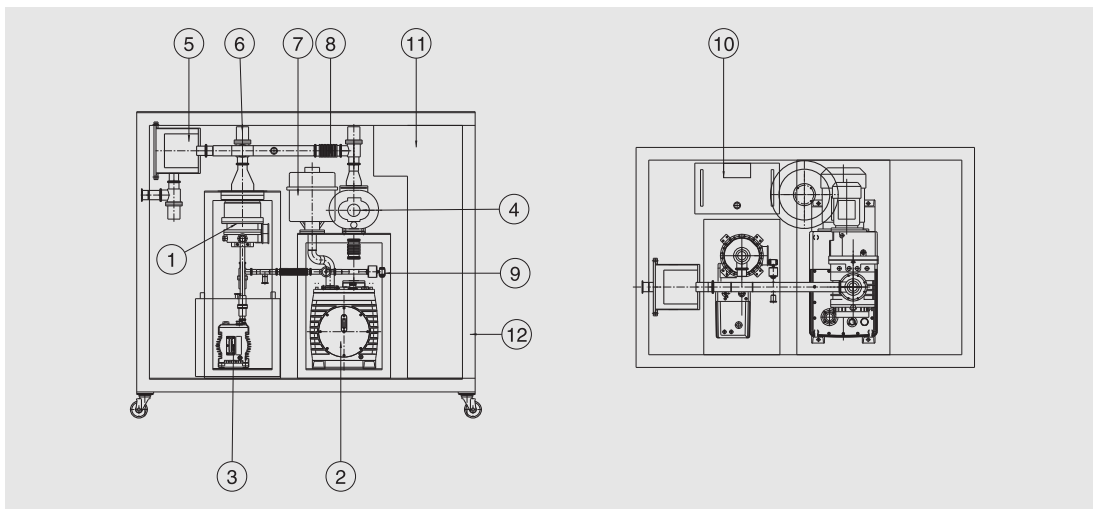

Description

- | | |
|--------------------------|-----------------|
| ① TURBO VACUUM PUMP | ⑦ OIL MIST TRAP |
| ② OIL ROTARY VACUUM PUMP | ⑧ BELLOWS TUBE |
| ③ OIL ROTARY VACUUM PUMP | ⑨ LEAK VALVE |
| ④ BOOSTER VACUUM PUMP | ⑩ LEAK DIRECTOR |
| ⑤ INLET FILTER | ⑪ CONTROL BOX |
| ⑥ PNEUMATIC ANGLE VALVE | ⑫ FRAME |

VACUUM GAUGES



Measurement Range of KVC Vacuum Gauge

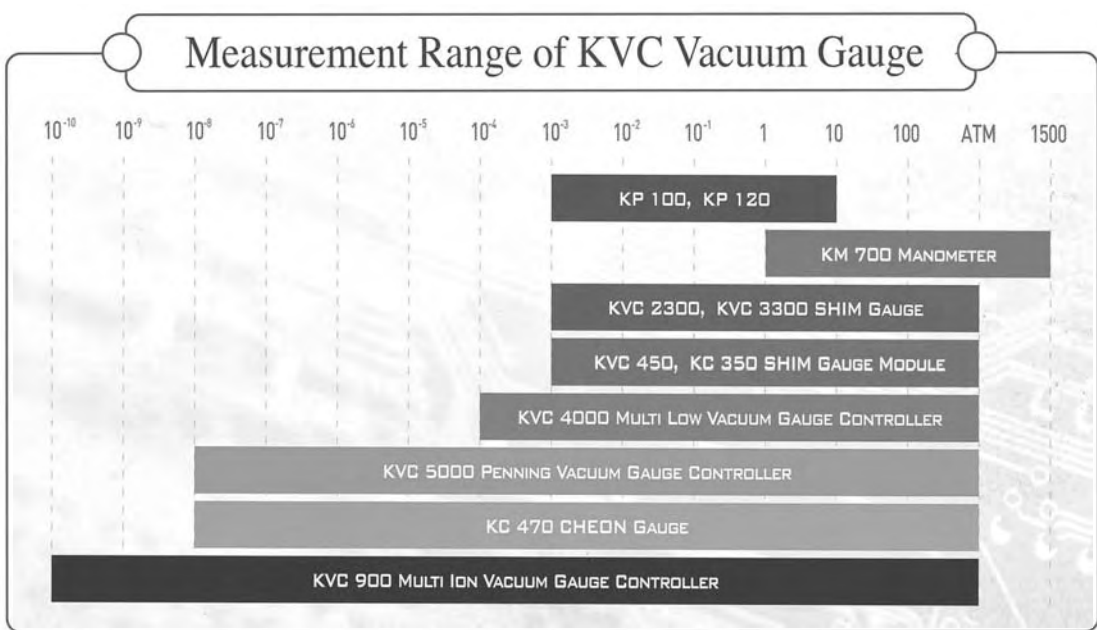

VACUUM GAUGES

Indicator

KP 100 Pirani



KVC 100 Pirani Gauge Indicator

Controller

- Sensor type : Pirani
- Measurement Range : 20Torr~1mTorr
- Unit : mTorr

Pirani Gauge

- Gas Calibration : Air or N₂
- Bake Out Temp : 100°C in Air or Vacuum
- Cable : Multi Conductor Shield Cable
- Fitting : 1/8 NPT
- Adaptor Fitting Available
- NW16KF, NW25KF, 15mm O.D, 19mm O.D

Monitoring Software

Function

- Available connection of Max. 16 Gauges
- Realtime monitoring
- Storage of monitoring data
- Zoom in & out at a part of graph you want to check
- Print

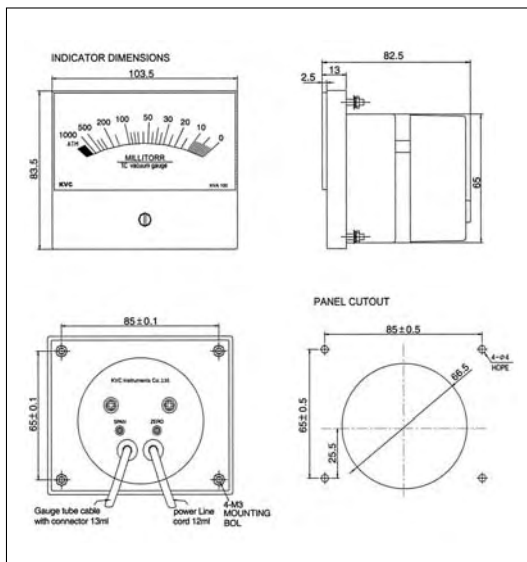

KM 700



KVC 700 Digital Manometer Indicator

Controller

- Sensor type : Manometer
- Measurement Range : 1Torr~1500Torr
- Standards Analog Output & Relay 2-Set Points
- Optional : RS232, 485
- Unit : Torr & kPa

Sensor

- Output Signal : 4~20mA
- Material : All Part 316 or 304S.S
- Cable Connector : 9Pin D-Sub Connector
- Fitting : 1/8 NPT, NW16, NW25, 15m O.D, 1.33"CF, 1/4"VCR

Dimension

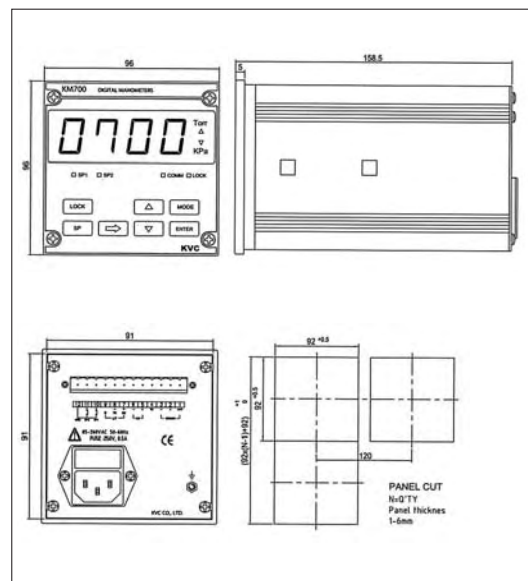

VACUUM GAUGES

Controller

KP 120



KP 120 Digital Pirani Vacuum Gauge Controller

Controller

- Measurement range : 20Torr~1.0E-03Torr
- Sensor conection : Pirani
- Input power : Free voltage (80Vac~230Vac)
- Standard analog output & Relay 2-setpoints
- Unit : Torr & Pascal
- Optional : RS232 or RS422/485

Pirani gauge

- Gas Calibration : Air or N2
- Sensor type : Thermal conductive
- Bake Out Temp : 100°C in Air vacuum
- Cable : 9pin D-Sub Connector, Multi Conductor Shield Cable
- Cable length : 3m(standard), 50m(Maximum)
- Fitting : 1/8NPT, NW16, NW25, 15m, O.D, 1.33"CF, 2.75"CF, 1/4" VCR

Dimension(KVC 2300, 3300, KP120)

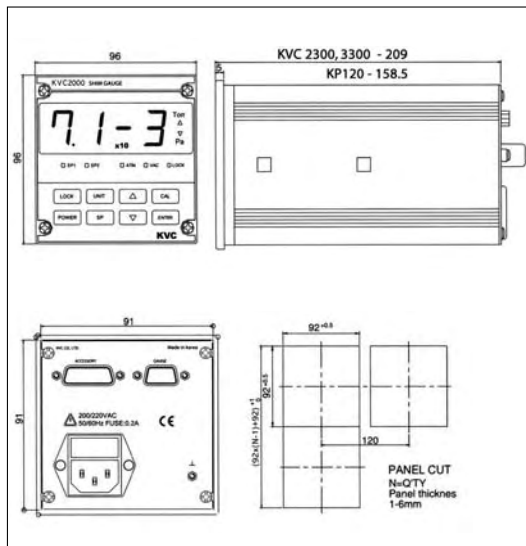

KVC 2300



KVC 2300 Digital SHIM Vacuum Gauge Controller

Controller

- Sensor type : SHIM Gauge
- Measurement Range : 1000Torr~1.0E-03Torr
- Standards Analog Output & Relay 2-Set Points
- Unit : Torr & Pascal
- Input power : Freevoltage(80Vac ~ 230Vac)
- Optional : RS232, RS422/485

SHIM Gauge

- Gas Calibration : Air or N2
- Bake Out Temp : 100°C in Air or Vacuum
- Cable : 9pin D-Sub Connector, Multi Conductor Shield Cable
- Cable length : 3m (Standard), 50m (Maximum)
- Fitting : 1/8 NPT, NW16, NW25, 15m O.D, 1.33"CF, 2.75"CF, 1/4"VCR
- Gauge axis must be horizontal to provide accurate measurement above 1 Torr

KVC 3300



KVC 3300 Digital SHIM Vacuum Gauge Controller

Controller

- Sensor type : SHIM Gauge
- Measurement Range : 1000Torr~1mTorr
- Standards Analog Output & Relay 2-Set Points
- Unit : mTorr
- Input power : Freevoltage(80Vac ~ 230Vac)
- Optional : RS232, RS422/485

SHIM Gauge

- Gas Calibration : Air or N2
- Bake Out Temp : 100°C in Air or Vacuum
- Cable : 9pin D-Sub Connector, Multi Conductor Shield Cable
- Cable length : 3m (Standard), 50m (Maximum)
- Fitting : 1/8 NPT, NW16, NW25, 15m O.D, 1.33"CF, 2.75"CF, 1/4"VCR
- Gauge axis must be horizontal to provide accurate measurement above 1 Torr

VACUUM GAUGES

Module / Controller

KVC 350



KVC 350 SHIM Gauge Compact Module

■ Specifications

- Measurement Range : 1000Torr~1.0E-03Torr
- Analog Output : 1V/decade, 0~6 Vdc
- Input Power : +24Vdc, 2Watts max
- Fitting : 1/8" NPT, 15mm O.D, NW16KF, NW25KF, 1.33"CF, 2.75"CF, 1/4"VCR
- Gauge axis must be horizontal to provide accurate measurement above 1 Torr

KVC 450



KVC 450 SHIM Gauge Compact Module

Specifications

- Measurement Range : 1000Torr~1.0E-03Torr
- Analog Output : 1V/decade, 0~6 Vdc
- Input Power : +24Vdc, 2Watts max
- Standard 2-Set Point
- Optional : RS 232, RS 485
- Fitting : 1/8" NPT, 15mm O · D, NW16KF, NW25KF, 1.33"CF, 2.75"CF, 1/4"VCR
- Gauge axis must be horizontal to provide accurate measurement above 1 Torr

KVC 4000



KVC 4000 Multi Low Vacuum Gauge Controller

Controller

- Channel : Standard 2ch' SHIM Gauge
Max. 4ch' SHIM Gauge
- Green LED
- Unit : Torr & Pa
- Standard Analog output
- Cable length : 3m ~50m
- Power input : 100Vac / 230Vac(by user selection)
250Watts, 50 or 60Hz
- Optional : Relay 6-setpoint
RS232 or 485 Interface

SHIM Gauge

- Measurement Range : 1000Torr ~ 1.0E~03 Torr
- Analog Output : 1V/decade, 0 ~ 6 Vdc
- Maximum Cable Length : ~ 50m(170ft)
- Fitting : 1/8" NPT, 15mm O.D, NW16KF, NW25KF, 1.33"CF, 2.75"CF, 1/4"VCR

Controller Dimension

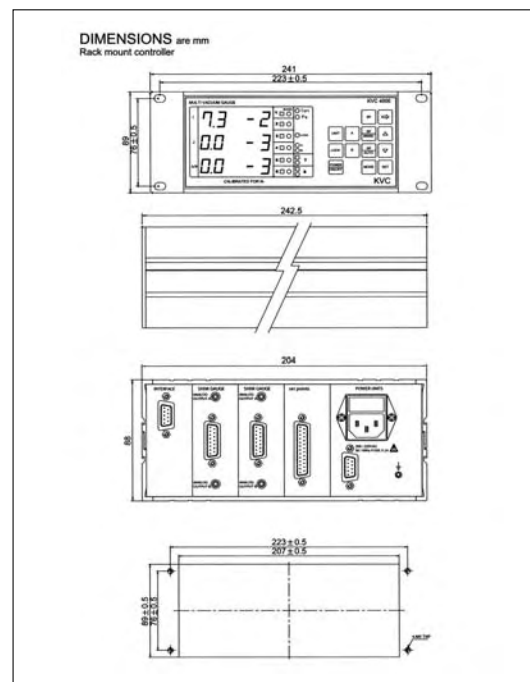

VACUUM GAUGES

KVC 5000 / KC 470

KVC 5000



KVC 5000 Penning Vacuum Gauge

Controller

- Channel : 1ch' PG & 2ch' SHIM Gauge
- Green LED
- Unit : Torr & Pa/Standard Analog output
- Power input : 100Vac / 230Vac(by user selection)
250Watts, 50 or 50Hz
- Optional : Relay 6-setpoint, RS232 OR 485 Interface

Penning Vacuum Gauge

Pressure Range

- Maximum Measurement Limit : 1.0E-08 Torr
- Minimum Measurement Limit : 1.0E-03 Torr
- Maximum Cable length : 3m(10ft.) ~ 60m(200ft.)
- Analog Output : 1V/decade, 0 ~ 7VDC

Low Vacuum Gauge

SHIM Gauge Pressure Range

- Measurement Range : 1.0E-03 ~ 1000Torr
- Analog Output : 1V/decade, 0 ~ 6VDC
- Cable length : 3meter (Standard), 50meter (Maximum)
- Fitting : 1/8NPT, NW16KF, NW25KF, 15m O.D.,
1.33"CF, 2.75"CF, 1/4"VCR
- Gauge axis must be horizontal to provide accurate measurement above 1Torr

Controller Dimension

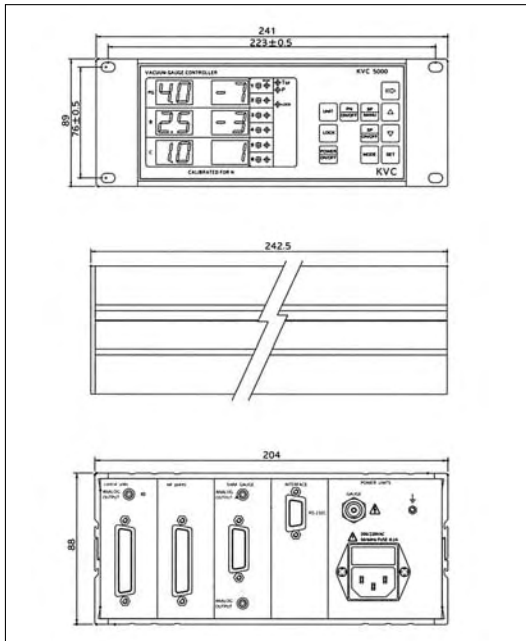

KC 470



KC 470 CHEON Gauge

Specification

- Measurement range : 1000Torr~1.0E-08Torr
- Sensor type : Combined Penning,
Pirani and absolute Silicon sensor
- Input power : +24Vdc
- Standard analog output & Relay 2-setpoints
- Mini 4-digit display windows
- Optional : RS485

Dimension

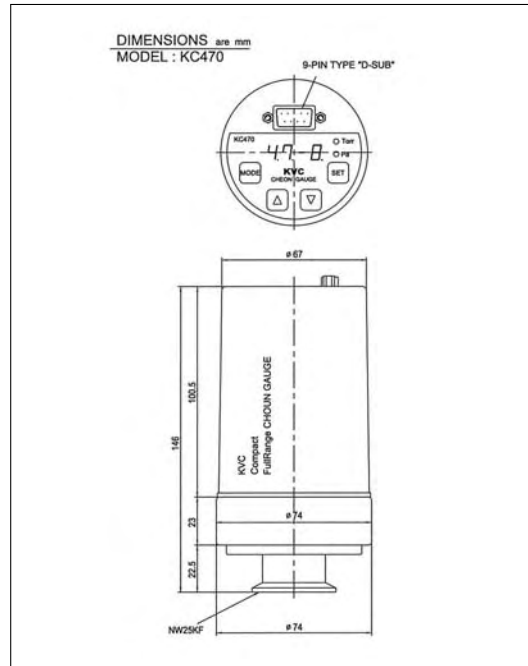

VACUUM GAUGES

KVC 900

KVC 900 Multi Ionization Vacuum Gauge's Specification.



Controller

- Channel : Max,2ch' IG & 2ch' SHIM Gauge
- Green LED
- Unit : Torr & Pa
- Standard Degas & Analog output
- Emission current : 0.1, 1, 10mA
- Power input : 100Vac / 230Vac(by user selection)
250Watts, 50 or 60Hz
- Optional : Relay 6-setpoint
RS232 or 485 Interface
Additional IG
Remote I/O

Dimension

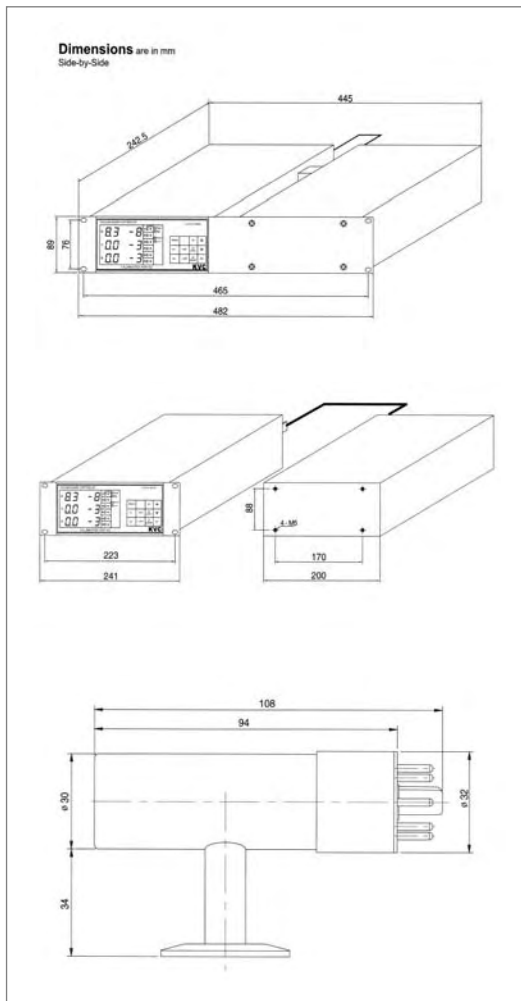

B-A Ionization Vacuum Gauge

Pressure Range

- Maximum Measurement Limit : 1.0E-10 Torr
- Minimum Measurement Limit: 1.0E-03 Torr
- Available Cable length: 3m(10ft.) ~ 60m(200ft.)
- Analog Output : 1V/decade, 0~7VDC

Low Vacuum Gauge

SHIM Gauge Pressure Range

- Measurement Range : 1.0E-03~1000Torr
- Analog Output : 1V/decade, 0~6VDC
- Cable length : 3meter(Standard), 50meter(Maximum)
- Fitting : 1/8NPT, NW16KF, NW25KF, 15m O.D,
1.33"CF, 2.75"CF, 1/4 "VCR
- Gauge axis must be horizontal to provide accurate measurement above 1 Torr

Mass Flow Controller

MFC

Mass flow controller / meter



Applications

- Total Industry
- Precision Gas Blending & Analyzing
- Gas Injection on Surface treatment Industry (PVD, CVD, Reactor, etc)
- Semiconductor Industry
- Component Leak Detection
- Research and Development
- High pressure Industry
- Optical Fiber
- Fuel Cell
- Reactor System
- Gas mixing System
- Laboratory

Specifications

Model	M2030VA	M3030VA	M2100VA	M3100VA
Range (N2)	5sccm ~ 30slpm		30 ~ 100slpm	
ResponseTime	≤3 sec		≤3 sec	
Accuracy	±1% FS		±1% FS	
Repeatability	±0.25% FS		±0.25% FS	
In / out signal	0~5Vdc	0~5Vdc or 4~20mA	0~5Vdc	0~5Vdc or 4~20mA
Supply Power	±15Vdc, 350mA		a±15Vdc, 350mA	
Max operating pressure	≤90 bar		a≤90 bar	
Max operating Temp	0~50℃		0~50℃	
Leak rate	1x10 ⁻⁹ atm · cc/sec		1x10 ⁻⁹ atm · cc/sec	
Control Range	5~100% for max range		5~100% for max range	

VACUUM PUMP ACCESSORIES

Oil Mist Trap

TMF Series



WSO Series



Technical Data

MODEL	표준유량(L/min)	Filter Element	ØA	B	C	D	E
TMF-12	200	Ø62×(26+50L)	95	NW25	NW25	100	136
TMF-36	600	Ø80×(35+71L)	120	NW25	NW25	130	166
TMF-90	1500	Ø120×(45+190L)	160	NW40	NW40	160	210

Dimensions

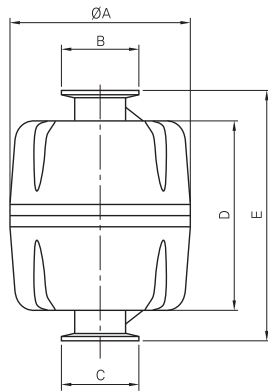

TMF-36

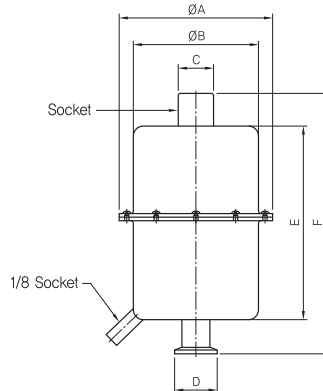

WSO 200~1500

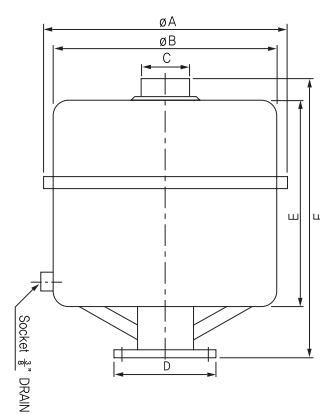

WSO 2500~7500

Technical Data

MODEL	표준유량(L/min)	Filter Element		ØA	ØB	C	D	E	F
		No	수량						
WSO-200	200	Ø75×75	1	115	90	20A	NW25	107	165
WSO-600	600	Ø100×95	1	148	122	25A	NW25	143	180
WSO-1000	1000	Ø100×145	1	148	122	40A	NW40	191	260
WSO-1500	1500	Ø100×195	1	148	122	40A	NW40	240	310
WSO-2500	2500	Ø100×145	3	300	270	Socket 2"	VG65	275	370
WSO-4500	4500	Ø100×145	5	380	350	Socket 2 1/2"	VG80	278	393
WSO-7500	7500	Ø100×195	5	380	350	Socket 3"	VG100	328	445
WSO-15000	15000	Ø100×300	7	450	400	VF125	VG125	440	595

VACUUM VALVES

Angle / In-Line Valves

Angle Valves

(Manually Operated)

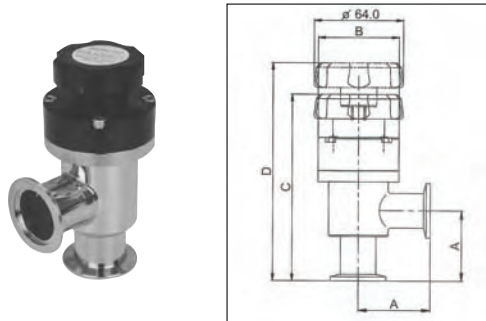

Specification

Model Number	MBK-016-A	MBK-025-A	MBK-040-A	MBK-050-A	MBK-063-A
Port Type	NW16KF	NW25KF	NW40KF	NW50KF	NW63KF
Stroke (mm)	13	13	20	25	26
A	54.6	51.5	61	86	88
B	Ø58	Ø58	Ø76	Ø89	Ø99
C	142	137	162	191	204
D	165	160	193	234	259

Angle Valves

(Pneumatically Actuated-Double)

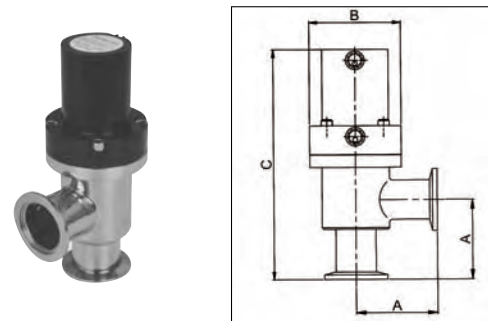

Specification

Model Number	PSK-016-A	PSK-025-A	PSK-040-A	PSK-050-A
Port Type	NW16KF	NW25KF	NW40KF	NW50KF
Stroke (mm)	13	13	20	25
A	54.6	51.5	61	86
B	Ø58	Ø58	Ø76	Ø89
C	154	149	187	231
D	1/8" PT	1/8" PT	1/8" PT	1/8" PT

In-Line Valves

(Manually Operated)

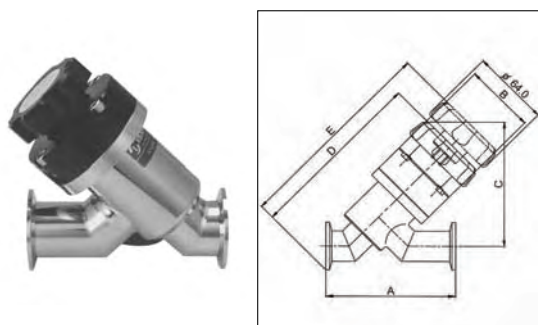

Specification

Model Number	MBK-016-L	MBK-025-L	MBK-040-L	MBK-050-L
Port Type	NW16KF	NW25KF	NW40KF	NW50KF
Stroke (mm)	13	13	20	25
A	101.6	106.7	130.0	117.8
B	Ø58	Ø58	Ø76	Ø89
C	121	124	150	174
D	143	147	207	209
E	166	170	238	252

In-Line Valves

(Pneumatically Actuated-Double)

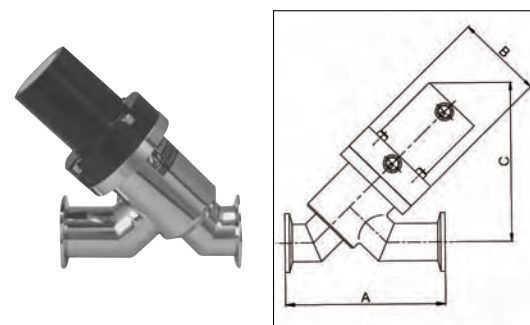

Specification

Model Number	PSK-016-L	PSK-025-L	PSK-040-L	PSK-050-L
Port Type	NW16KF	NW25KF	NW40KF	NW50KF
Stroke (mm)	13	13	20	25
A	101.6	106.7	130.0	117.8
B	Ø58	Ø58	Ø76	Ø89
C	124	128	169	204
D	155	160	207	250
E	1/8" PT	1/8" PT	1/8" PT	1/8" PT

VACUUM VALVES

Right Angle Valves

LV-M Series

(Right-Angle Valves)

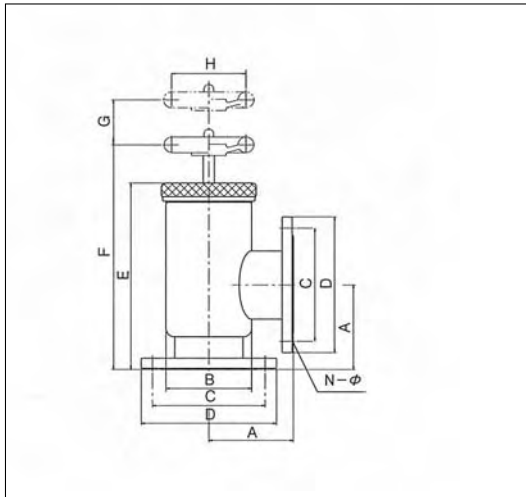

Features

- Compact structure
- Low cost
- Body material : Stainless steel(Ni plating:Option)
- Seal material : NBR(Option: viton)

Dimensions

MODEL	A	B	C	D	E	F	G	H	N-Ø	Weight(kg)
LV-1M	55	48.6	70	90	98.5	124	20	66	4-10	1.5
LV-2M	75	76.5	100	120	134	159.5	30	66	4-10	3.4
LV-3M	95	114.3	135	160	187	226.5	45	123	4-12	7.8
LV-4M	110	139.8	160	185	212	251.5	58	123	8-12	11.5
LV-6M	130	216.3	210	235	286	326.5	85	142	8-12	21.5
LV-8M	175	267.4	270	300	371	454	115	225	8-15	45.2
LV-10M	200	318	320	350	529	605	180	225	12-15	60.5
LV-14M	260	406	420	450	738	805	230	250	12-15	106
LV-18M	350	510	535	575	738	-	-	-	16-19	243
LV-22M	450	612	640	680	830	-	-	-	16-19	298
LV-26M	450	690	750	800	940	-	-	-	20-23	425

LV-A Series

(Right-Angle Valves)

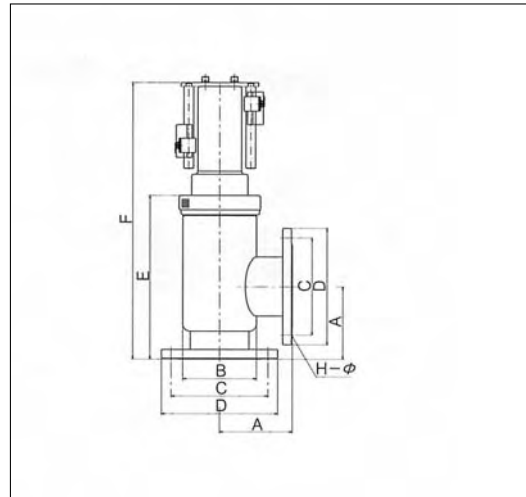

Features

- Compact structure
- Low cost
- Body material : Stainless steel(Ni plating:Option)
- Seal material : NBR(Option: viton)
- Inter-lock control
(mounted with a magnet in the cyclinder)

Dimensions

MODEL	A	B	C	D	E	F	Air inlet port	Weight(kg)
LV-1A	55	48.6	70	90	98.5	169.5	PT $\frac{1}{8}$	1.6
LV-2A	75	76.5	100	120	134	218.5	PT $\frac{1}{8}$	3.8
LV-3A	95	114.3	135	160	187	283	PT $\frac{3}{8}$	8.6
LV-4A	110	139.8	160	185	212	333	PT $\frac{3}{8}$	13.2
LV-6A	130	216.3	210	235	286	449	PT $\frac{1}{2}$	30.5
LV-8A	175	267.4	270	300	371	649	PT $\frac{1}{2}$	54
LV-10A	200	318	320	350	419	657	PT $\frac{1}{2}$	70
LV-14A	260	406	420	450	529	822	PT $\frac{1}{2}$	118
LV-18A	350	510	535	575	700	1210	PT $\frac{1}{2}$	229
LV-22A	450	612	640	680	830	1490	PT $\frac{1}{2}$	281
LV-26A	450	690	750	800	930	1715	PT $\frac{1}{2}$	415

VACUUM VALVES

Circular Gate Valve



Specification

Material

- Body : 300 Series sst
- Gate : 300 Series sst
- Air Cylinder : Aluminum
- Bellows : AM-350

Sealing

- Bonnet Seal : Gasket / Viton
- Gate Seal : Viton

Mounting Position : Any

(High size : vertical & horizontal)

Cycles Until First Service

- Cycles : 100,000
- Service : 1 Year

Actuator

<Pneumatic>

- Air Pressure 70 to 100psig (High size 80 to 100psig)
- Air controll Pilot check Valve
- Position Indicators 20mA, 110/220 V AC or 24V DC

<Pneumatic>

- Hand Wheel Type

Temperature

- Body : 250°C (open)
- Gate : 150°C
- Actuator : 60°C

Leak Rate

- Body : 1×10^{-9} mbar.l / sec
- Gate : 1×10^{-9} mbar.l / sec

Retangular Gate Valve



① Type

- R : Rectangular gate valve
- D : Door gate valve

② Slit Hight(mm)

③ Slit Width(mm)

④ Body material

- 3 : SUS304
- 6 : Almunom 6061

⑤ Seal material

- 1 : Viton
- 2 : Silicon
- 3 : Other sealing matenal on request

Specification

- Body Material : Aluminum + Hard Anodized
- Gate Seal Plate : Aluminum + Hard Anodized
- Vacuum Side Seal Material : Viton O-Ring
 - * Other Sealing Material On Request
- Leak Rate : $< 2 \times 10^{-8}$ std.cc/sec
- Operate Pressure : 35~90 psi
- Body Temperature : $\leq 150^\circ\text{C}$
- Operation Type : Pneumatic
- Electric Power With Positon Sensor : DC24V
- Mount Position : Actuator Downward, Verical Stroke
- Cycle Until First Service : ≥ 3 Million

VACUUM VALVES

Circular Gate Valves

Port	Model	Flange	Bonnet Seal	Actuator	Ordering No
------	-------	--------	-------------	----------	-------------

1.5"	SCG-40P	CF 2.75"	Gasket	Pneumatic	SC04010-G
			O-ring		SC04010
		NW 40 KF	O-ring		SC04020
	SCG-40M	CF 2.75"	Gasket		SC04011-G
			O-ring		SC04011
		NW 40 KF	O-ring		SC04021

2.5"	SCG-63P	CF 4.5"	Gasket	Pneumatic	SC06310-G
			O-ring		SC06310
		NW 63 ISO	O-ring		SC06320
		ASA 2 ANSI	O-ring		SC06330
	SCG-63M	CF 4.5"	Gasket	Manual	SC06311-G
			O-ring		SC06311
		NW 63 ISO	O-ring		SC06321
		ASA 2 ANSI	O-ring		SC06331

4"	SCG-100P	CF 6"	Gasket	Pneumatic	SC10010-G
			O-ring		SC10010
		NW 100 ISO	O-ring		SC10020
		ASA 4 ANSI	O-ring		SC10030
		JIS 100 VF	O-ring		SC10040
	SCG-100M	CF 6"	Gasket	Manual	SC10011-G
			O-ring		SC10011
		NW 100 ISO	O-ring		SC10021
		ASA 4 ANSI	O-ring		SC10031
		JIS 100 VF	O-ring		SC10041

6"	SCG-160P	CF 8"	Gasket	Pneumatic	SC16010-G
			O-ring		SC16010
		NW 160 ISO	O-ring		SC16020
		ASA 6 ANSI	O-ring		SC16030
		JIS 150 VF	O-ring		SC16040
	SCG-160M	CF 8"	Gasket	Manual	SC16011-G
			O-ring		SC16011
		NW 160 ISO	O-ring		SC16021
		ASA 6 ANSI	O-ring		SC16031
		JIS 150 VF	O-ring		SC16041

Port	Model	Flange	Bonnet Seal	Actuator	Ordering No
------	-------	--------	-------------	----------	-------------

8"	SCG-200P	CF 10"	Gasket	Pneumatic	SC20010-G
			O-ring		SC20010
		NW 200 ISO	O-ring		SC20020
		ASA 6 ANSI	O-ring		SC20030
	SCG-200M	CF 10"	Gasket	Manual	SC20011-G
			O-ring		SC20011
		NW 200 ISO	O-ring		SC20021
		ASA 6 ANSI	O-ring		SC20031
		JIS 200 VF	O-ring		SC20040
			O-ring		SC20041

10"	SCG-250P	CF 12"	Gasket	Pneumatic	SC25010-G
			O-ring		SC25010
		NW 250 ISO	O-ring		SC25020
		ASA 10 ANSI	O-ring		SC25030
		JIS 250 VF	O-ring		SC25040
	SCG-250M	CF 12"	Gasket	Manual	SC25011-G
			O-ring		SC25011
		NW 250 ISO	O-ring		SC25021
		ASA 10 ANSI	O-ring		SC25031
		JIS 250 VF	O-ring		SC25041

12"	SCG-300P	CF 14"	Gasket	Pneumatic	SC32010-G
			O-ring		SC32010
		NW 320 ISO	O-ring		SC32020
		ASA 10 ANSI	O-ring		SC32030
		JIS 300 VF	O-ring		SC32040

16"	SCG-400P	JIS 400 VF	O-ring	직선	SC40040
			O-ring	LINK	SC40041

18"	SCG-450P	JIS 450 VF	O-ring	직선	SC45040
-----	----------	------------	--------	----	---------

20"	SCG-500P	JIS 500 VF	O-ring	직선	SC50040
-----	----------	------------	--------	----	---------

22"	SCG-550P	JIS 550 VF	O-ring	직선	SC55040
-----	----------	------------	--------	----	---------

* SPECIAL 사양 제작 가능

VACUUM VALVES

Circular Gate Valves

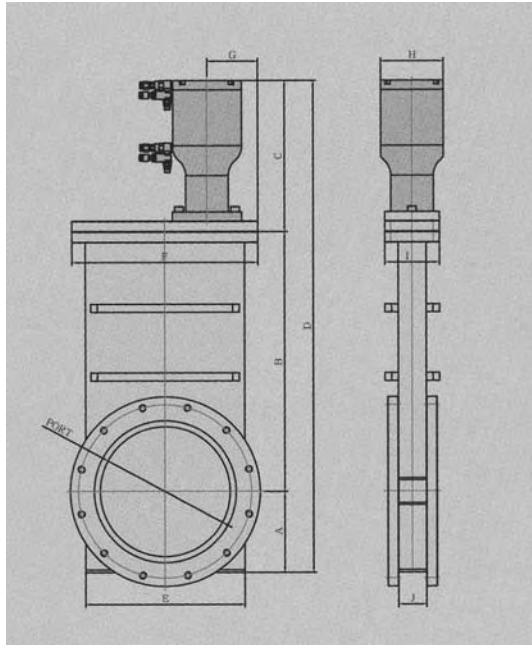

Pneumatic

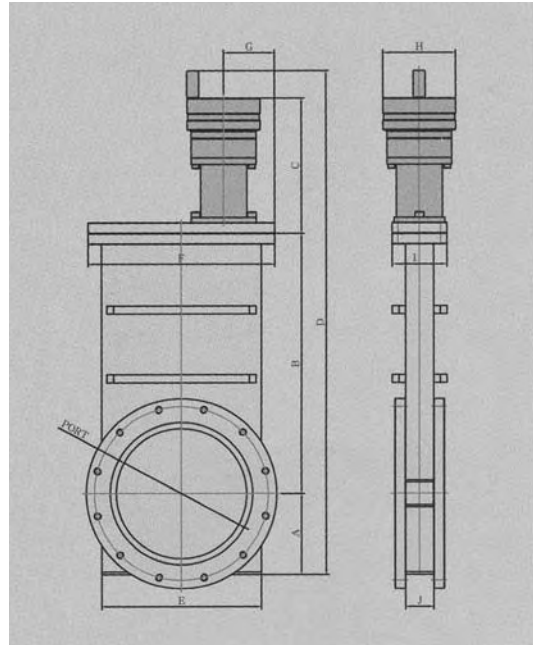

Manual

Pneumatic Gate Valve

PortSize	A	B	C	D	E	F	G	H	I	J
1.5" (38)	38.5	103.5	109.5	251.5	69.5	92	30.5	52	50	27
2.5" (63.5)	52.5	142	133.5	328	99.5	132	43	64	64	32.5
4" (100)	74.5	223	160.5	458	140	184	61	64	82	40
6" (145)	99	305	190	594	190	230	68	77	82	42
8" (195)	121.5	389.5	227	738	239	279	76	94	82	42
10" (245)	149	489	273	911	294	334	95	124	89	48
12" (305)	188	590	277	1055	368	410	105	124	94	49.6
14" (356)	220	677	298	1195	426	468	116	154	94	51.6
16" (407)	256	796	359	1427	485	550	154	174	140	66.2
18" (458)	283	857	716	1856	543	615	307.5	116	140	66.2
20" (508)	313	926	769	2008	610	690	345	116	140	66.2
22" (560)	335	1011	836	2202	652	725	362.5	145	150	68.2

Manual Gate Valve

PortSize	A	B	C	D	E	F	G	H	I	J
1.5" (38)	38.5	103.5	86	268.7	69.5	92	30.5	48	48	25.4
2.5" (63.5)	52.5	142	94	329.5	99.5	132	43	64	64	32.5
4" (100)	74.5	223	143	482	140	184	61	95	82	40
6" (145)	99	305	154.5	599.2	190	230	68	79	82	42
8" (195)	121.5	389.5	194.5	746.5	239	279	76	109	82	42
10" (245)	149	489	226.5	905.2	294	334	95	117	89	48

VACUUM VALVES

Flange Dimension

CF Flange							
PortSize	Flange	A	B	C	D	E	F
1.5"	CF2.75"	58.7	38	70	12.7	6-M6	60
2.5"	CF4.5"	92.1	63.5	114	17.5	8-M8	45
4"	CF6"	130.3	100	152	20	16-M8	22.5
6"	CF8"	181	145	203	22	20-M8	18
8"	CF10"	231.8	195	253	22	24-M8	15
10"	CF12"	284	245	305	28	32-M8	11.25
12"	CF14"	325.4	305	355.6	28	30-M8	12

NW Flange							
PortSize	Flange	A	B	C	D	E	F
2.5"	NW63ISO	110	63.5	130	12	4-M8	90
4"	NW100ISO	145	100	165	12	8-M8	45
6"	NW160ISO	200	145	225	16	8-M10	45
8"	NW200ISO	260	195	285	16	12-M10	30
10"	NW250ISO	310	245	335	16	12-M10	30
12"	NW320ISO	395	305	425	22	12-M12	30

ANSI Flange							
PortSize	Flange	A	B	C	D	E	F
2.5"	ASA2 ANSI	120.6	63.5	152	12	4-M10	90
4"	ASA4 ANSI	190.5	100	228.6	12.7	8-M10	45
6"	ASA6 ANSI	241.3	145	279.4	16	8-M20	45
8"	ASA6 ANSI	241.3	200	279.4	16	8-M20	45
10"	ASA10 ANSI	362	245	406.4	22	12-M20	30
12"	ASA10 ANSI	362	305	406.4	22	12-M20	30

KF Flange							
PortSize	Flange	A	B	C	D	E	F
1.5"	NW40KF	41.2	38	55	12.7		
2"	NW50KF	50.8	49	75	20		

JIS Flange							
PortSize	Flange	A	B	C	D	E	F
4"	JIS100	160	100	185	12	8-M10	45
6"	JIS150	210	145	235	16	8-M10	45
8"	JIS200	270	195	300	16	8-M12	45
10"	JIS250	320	245	350	18	12-M12	30
12"	JIS300	370	305	400	22	12-M12	30
14"	JIS350	420	356	450	24	12-M12	30
16"	JIS400	480	407	520	26	12-M16	30
18"	JIS450	535	458	575	26	16-M16	22.5
20"	JIS500	585	508	625	28	16-M16	22.5
22"	JIS550	640	560	680	30	16-M16	22.5

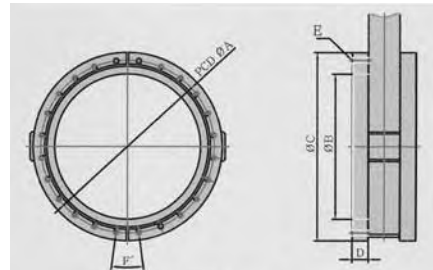

CF Flange

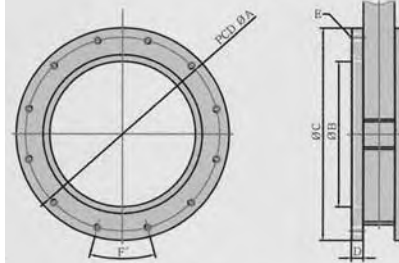

NW Flange

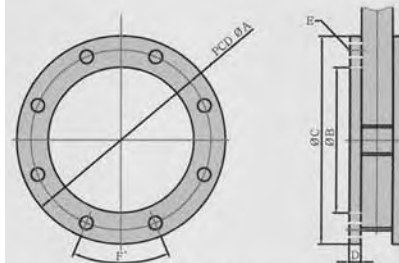

ANSI Flange

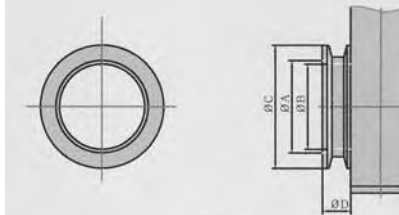

KF Flange

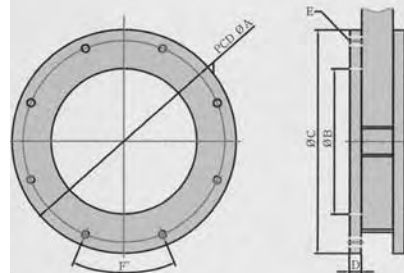

JIS Flange

VACUUM VALVES

SHV-E / UVCR-A Series

SHV-E Series

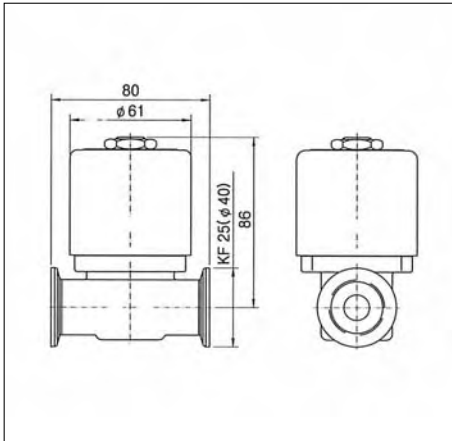

Features

- Body material is SUS and allowable usage in high vacuum range for small leakage rate.
- High operate in high vacuum condition and high pressure condition.
- Allowable various valve as like vacuum valve, leak valve

Technical Specification

ITEM	MODEL	SHV-25E
Operating Pressure Range(Pa)		$1.33 \times 10^{-6} \sim 2 \times 10^5$
Leak Rate(Pa.l /sec)		$< \times 10^{-8}$
Orifice		Ø8
Post Seal		Viton
Temperature Rate		0°C~55°C
Supply Voltage		AC 220V(50Hz/60Hz) DC 24V
Power Consumption		15W
Weight(kg)		0.98

UVCR-A Series

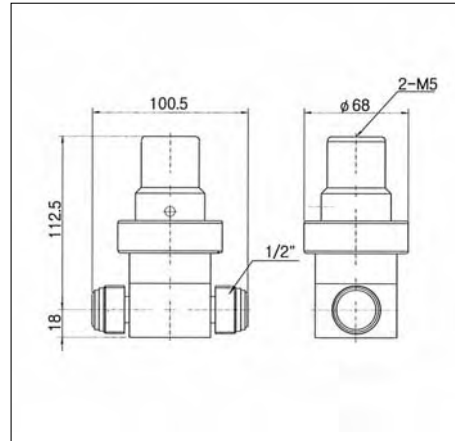

Features

- Body material is SUS and allowable usage in Ultra-High vacuum as bellows inside type and compact structure.
- It can use to valve for gas injection as pneumatic valve.
- Low cast.

Technical Specification

ITEM	MODEL	UVCR-8A
Compressed Air(kg/cm ²)		4~5
Operating Pressure Range(Pa)		$1.33 \times 10^{-8} \sim 2 \times 10^5$
Leak Rate(Pa.l /sec)		$< \times 10^{-8}$
Auto Switch		DC 24V
Post Seal		Viton
Metal Welded Bellows		SUS-316L
Connection Flange		VCR 1/2
Weight(kg)		0.5

VACUUM ACCESSORIES

Clamp / Ring

KF Quick Clamp

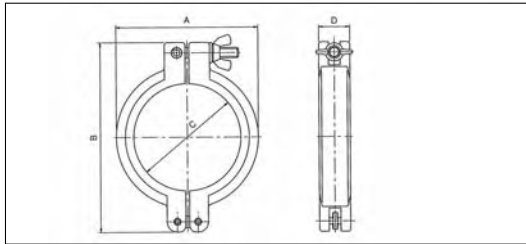

Specification

- Body Material : Aluminum

Technical Specification

Connection Type	A(mm)	B(mm)	C(mm)	D(mm)
KF 16 KCCR-16	45	61	22	16
KF 25 KCCR-25	55	72	32	16
KF 40 KCCR-40	72	90	48	18
KF 50 KCCR-50	96	123	63	25

KF Center Ring

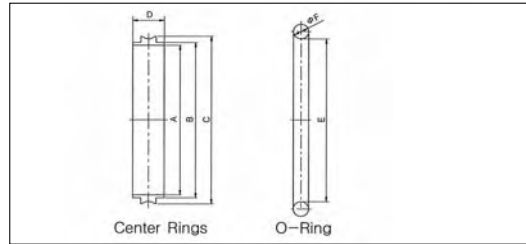

Specification

- Center Ring Material : Stainless(SUS-304)
- O-Ring Material : Viton

Technical Specification

Flange Type	A(mm)	B(mm)	C(mm)	D(mm)	E(mm)	F(mm)
KF 16 KCCR-16	16	17	20	8	18	3.9
KF 25 KCCR-25	25	26	30	8	28	3.9
KF 40 KCCR-40	40	41	44	8	42	3.9
KF 50 KCCR-50	50	52	57	8	55	3.9

KF Bored Flange

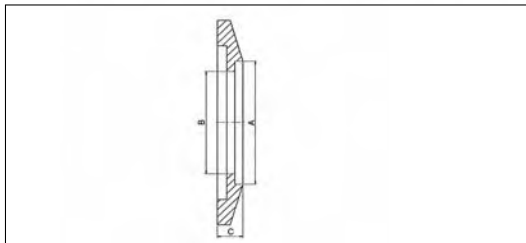

Specification

- Material : Stainless(SUS-304)

Technical Specification

Connection Type	A(mm)	B(mm)	C(mm)
KF 16 KCCBF-16	20	15.5	5
KF 25 KCCBF-25	28	24.5	5
KF 40 KCCBF-40	45	39.5	5
KF 50 KCCBF-50	55	49.5	5

KF Blank Flange

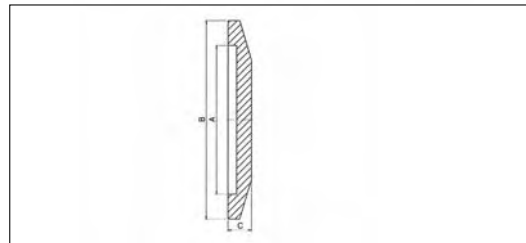

Specification

- Material : Stainless(SUS-304)

Technical Specification

Connection Type	A(mm)	B(mm)	C(mm)
KF 16 KCCBFB-16	17.2	30	5
KF 25 KCCBFB-25	26.2	40	5
KF 40 KCCBFB-40	41.2	55	5
KF 50 KCCBFB-50	52.2	75	5

VACUUM ACCESSORIES

Flange / Tube

KF Flange

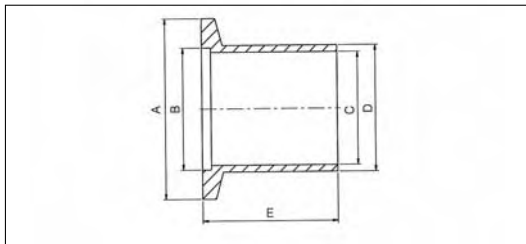

Specification

- Material : Stainless(SUS-304)

Technical Specification

Flange Type	A(mm)	B(mm)	C(mm)	D(mm)	E(mm)
KF 16 KCCF-16	30	17.2	16	20	30
KF 25 KCCF-25	40	26.2	25	28	30
KF 40 KCCF-40	55	41.2	40	45	30
KF 50 KCCF-50	75	52.2	50	55	30

KF Metal Bellows Tube

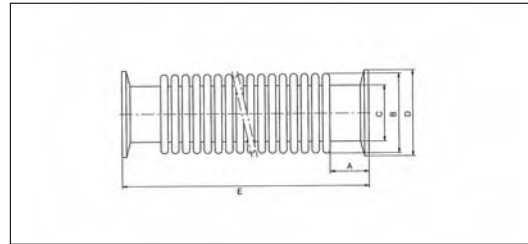

Specification

- Material : Stainless

Technical Specification

Flange Type	A(mm)	B(mm)	C(mm)	D(mm)	E(mm)
KF 25 KHBT-25	18	37	26	40	150 to 1000
KF 40 KHBT-40	18	55	40	55	150 to 1000
KF 50 KHBT-50	18	72	54	75	150 to 1000

KF 90° Elbows

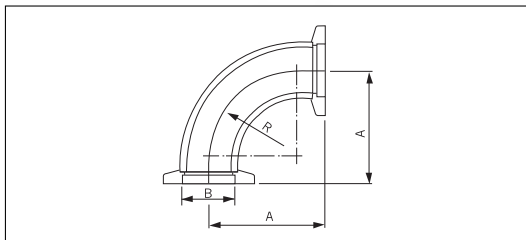

Technical Specification

Flange Type	A(mm)	B(mm)
KF 16 KFEL-16	40	16
KF 25 KFEL-25	50	25
KF 40 KFEL-40	65	40
KF 50 KFEL-50	75	50

KF Tees

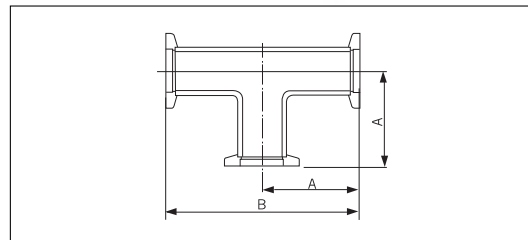

Technical Specification

Flange Type	A(mm)	D ₁ (mm)	D ₂ (mm)
KF 16 KHN-16	35	8	12
KF 25 KHN-25	40	12	20
KF 40 KHN-40	45	16	25
KF 50 KHN-50	50	16	25

VACUUM ACCESSORIES

Adaptor

KF 4-Way Crosses

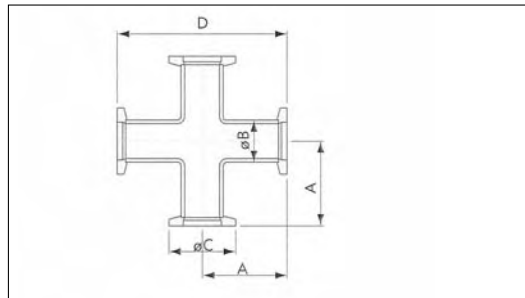

Technical Specification

Flange Type	A(mm)	B(mm)	C(mm)	D(mm)
KF 16 KFCA-16	38.1	19.05	30	76.2
KF 25 KFCA-25	51.4	25.4	40	102.8
KF 40 KFCA-40	61	38.1	55	122
KF 50 KFCA-50	80	50.8	75	160

KF-KF Conical Reducing Adaptor

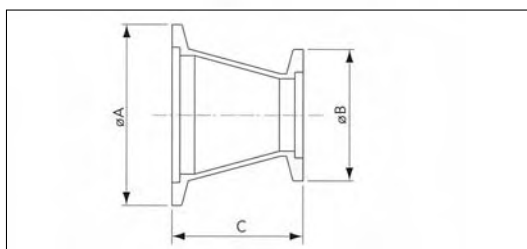

Technical Specification

Adaptor Type	A(mm)	B(mm)	C(mm)
KF 25 KA-16	40	30	40
KF 40 KA-16	55	30	40
KF 40 KA-25	55	40	40
KF 50 KA-16	75	30	40
KF 50 KA-28	75	40	40
KF 50 KA-40	75	55	40

KF Quick-Disconnect Adaptor

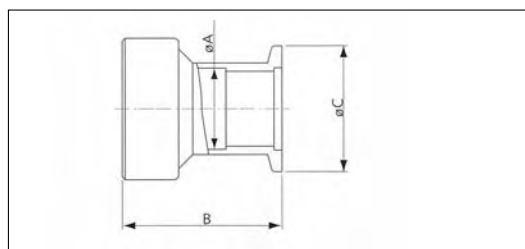

Technical Specification

Flange Type	A(mm)	B(mm)	C(mm)
KF 16 QDA-6	6.5	33.4	30
KF 16 QDA-12	13	36.5	30
KF 16 QDA-19	19.4	44.5	30
KF 25 QDA-12	13	36.5	40
KF 25 QDA-19	19.3	44.5	40
KF 25 QDA-25	25.7	50.8	40
KF 40 QDA-12	13	36.5	55
KF 40 QDA-19	19.3	44.5	55
KF 40 QDA-25	25.7	50.8	55
KF 40 QDA-38	38.4	60.3	55
KF 50 QDA-38	38.4	60.3	75
KF 50 QDA-50	51	60.3	75

VACUUM ACCESSORIES

Nipples

ISO Full Nipples

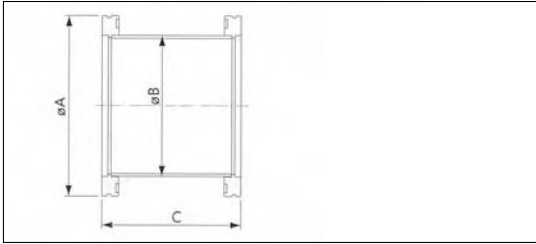

Technical Specification

Model No.	A(mm)	B(mm)	C(mm)
ISO 16 N	30	19.0	76
ISO 25 N	40	25.4	103
ISO 40 N	55	38.1	125
ISO 50 N	75	50.8	163
ISO 63 N	95	63.5	200
ISO 80 N	110	76.3	200
ISO 100 N	130	101.6	250
ISO 160 N	180	152.4	300

ISO 90° Elbows

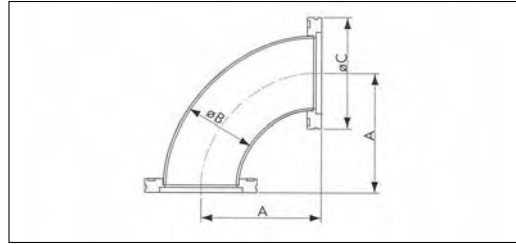

Technical Specification

Model No.	A(mm)	B(Ø)	C(Ø)
ISO 16 EL	30	19.0	38
ISO 25 EL	40	25.4	51
ISO 40 EL	55	38.1	55
ISO 50 EL	75	50.8	81
ISO 63 EL	80	63.5	95
ISO 80 EL	100	76.3	110
ISO 100 EL	130	101.6	130
ISO 160 EL	160	152.4	180

ISO Tees

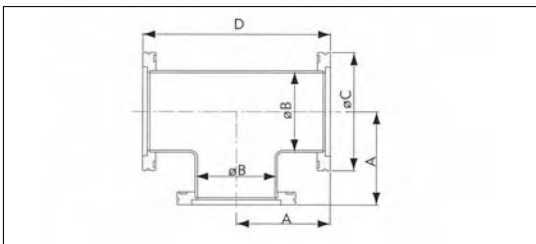

Technical Specification

Model No.	A(mm)	B(Ø)	C(Ø)	D(mm)
ISO 16 TA	38	19.0	30	76
ISO 25 TA	40	25.4	51	80
ISO 40 TA	55	38.1	55	110
ISO 50 TA	75	50.8	81	150
ISO 63 TA	80	63.5	95	160
ISO 80 TA	100	76.3	110	200
ISO 100 TA	130	101.6	130	260
ISO 160 TA	160	152.4	180	320

ISO 4-Way Crosses

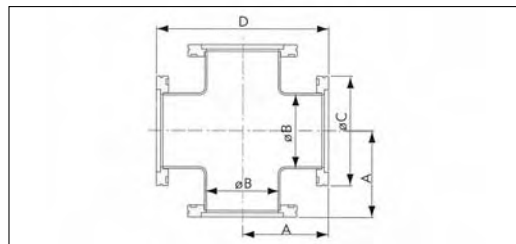

Technical Specification

Model No.	A(mm)	B(Ø)	C(Ø)	D(mm)
ISO 16 XA	38	19.0	30	76
ISO 25 XA	60	25.4	40	120
ISO 40 XA	62	38.1	55	124
ISO 50 XA	75	50.8	81	150
ISO 63 XA	80	63.5	95	160
ISO 80 XA	100	76.3	110	200
ISO 100 XA	130	101.6	130	260
ISO 160 XA	160	152.4	180	320

VACUUM ACCESSORIES

Clamps

Single Wall Clamp

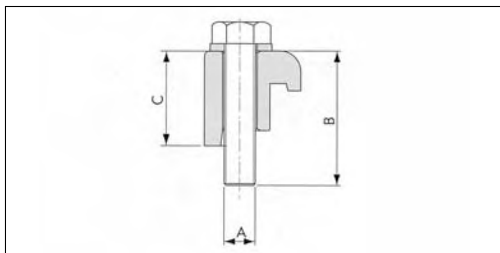

Technical Specification

Model No.	Material	A	B(mm)	C(mm)	Fit Flange
ISO 63-100SWC304	SUS304	M8	35	23	ISO 63 ISO 80 ISO 100
ISO 63-250SWC304	SUS304	M10	35	23	ISO 160 ISO 200 ISO 250
ISO 320-500SWC304	SUS304	M12	50	30	ISO 320 ISO 400 ISO 500
ISO 63-100SWCA	Aluminum	M8	35	23.5	ISO 63 ISO 80 ISO 100
ISO 160-250SWCA	Aluminum	M10	35	23.5	ISO 160 ISO 200 ISO 250
ISO 320-500SWCA	Aluminum	M12	50	30	ISO 320 ISO 400 ISO 500

Double Wall Clamp

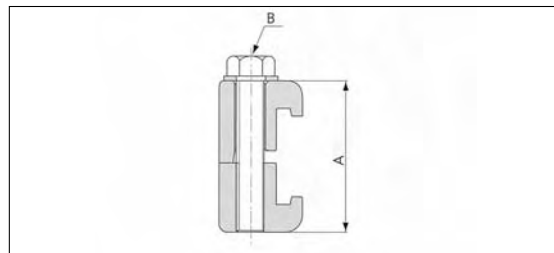

Technical Specification

Model No.	Material	A	B	Quantity	Fit Flange
ISO 63-100 DWCA	Aluminum	45	M8	4 4 4	ISO 63 ISO 80 ISO 100
ISO 160-250 DWCA	Aluminum	45	M10	4 6 6	ISO 160 ISO 200 ISO 250
ISO 320-500 DWCA	Aluminum	60	M12	8 8 12	ISO 320 ISO 400 ISO 500

Double Claw Clamp

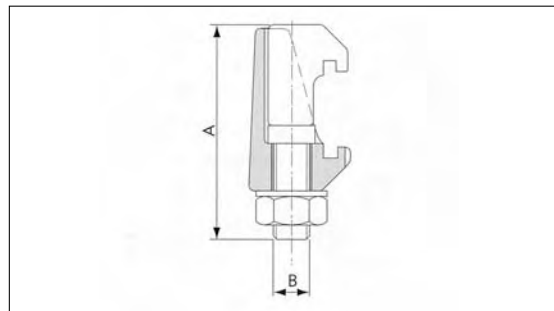

Technical Specification

Model No.	Material	A	B	Quantity	Fit Flange
ISO 63-250 DCC316	SUS316	61.5	M10	4 4 4 4 6 6	ISO 63 ISO 80 ISO 100 ISO 160 ISO 200 ISO 250
ISO 320-500 DCC316	SUS316	76	M12	8 8 12	ISO 320 ISO 400 ISO 500
ISO 630-DCC316	SUS316	86	M12	12	ISO 630

VACUUM ACCESSORIES

Nipples

CF Half Nipple

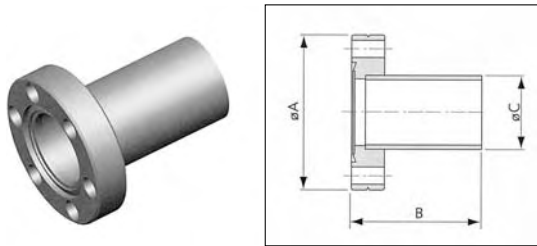

Technical Specification

ITEM No.	Flange Type(CF)		L(mm)
	mm	inch	
CF-HN40	34	1 1/8	40
CF-HN60	70	2 3/4	60
CF-HN80	86	3 3/8	80
CF-HN100	114	4 1/2	100
CF-HN110	152	6	110
CF-HN130	203	8	130
CF-HN170	253	10	170
CF-HN190	305	12	190
CF-HN250	336	13 1/4	250

CF Nipples

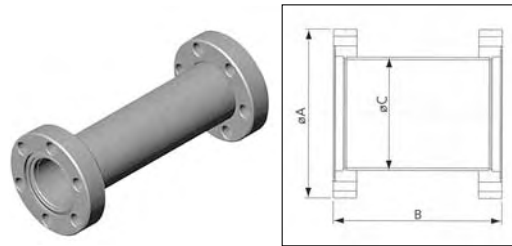

Technical Specification

ITEM No.	Flange Type(CF)		L(mm)
	mm	inch	
CF-HN80	34	1 1/8	80
CF-HN120	70	2 3/4	120
CF-HN160	86	3 3/8	160
CF-HN200	114	4 1/2	200
CF-HN220	152	6	220
CF-HN260	203	8	260
CF-HN340	253	10	340
CF-HN380	305	12	380
CF-FN500	336	13 1/4	500

CF 90° Elbows

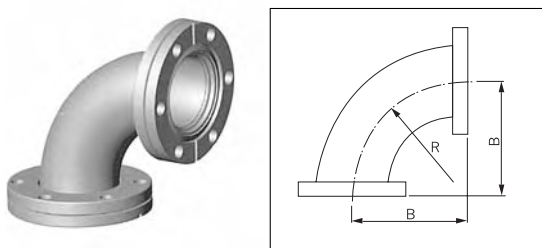

Technical Specification

ITEM No.	Flange Type	Tube O.D.(mm)	B(mm)
CF-RE16	1 1/8"	19	29
CF-RE35	2 3/4"	38.1	62
CF-RE50	3 3/8"	50.8	84
CF-RE63	4 1/2"	63.5	104
CF-RE100	6"	101.6	162
CF-RE150	8"	152.4	240
CF-RE200	10"	203.2	318
CF-RE250	12"	254.0	395

CF Tees

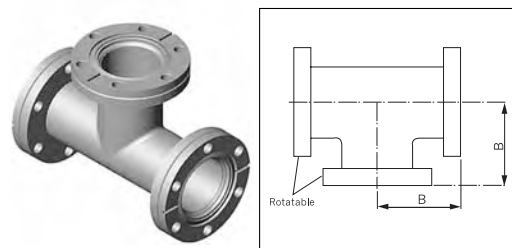

Technical Specification

ITEM No.	Flange Type	Tube O.D.(mm)	B(mm)
CF-TE16	1 1/8"	19.0	29
CF-TE35	2 3/4"	38.1	62
CF-TEL35	2 3/4"	38.1	66
CF-TE50	3 3/8"	50.8	85
CF-TEL50	3 3/8"	50.8	101
CF-TE63	4 1/2"	63.5	86
CF-TEL63	4 1/2"	63.5	105
CF-TE100	6"	101.6	110
CF-TEL100	6"	101.6	225
CF-TE150	8"	152.4	140
CF-TEL150	8"	152.4	166
CF-TE200	10"	203.2	191
CF-TE250	12"	254.0	255

VACUUM ACCESSORIES

Gasket

CF 4 Way Crosses

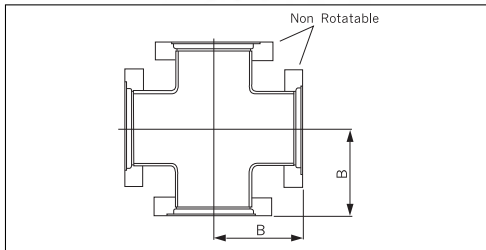

Technical Specification

ITEM No.	Flange Type	Tube O.D.(mm)	B(mm)
CF-FW16	1 $\frac{1}{8}$ "	19.0	29
CF-FW35	2 $\frac{3}{4}$ "	38.1	62
CF-FW50	3 $\frac{3}{8}$ "	50.8	85
CF-FWS63	4 $\frac{1}{2}$ "	63.5	86
CF-FWL63	4 $\frac{1}{2}$ "	63.5	105
CF-FWS100	6"	101.6	110
CF-FWL100	6"	101.6	225
CF-FWS150	8"	152.4	140
CF-FWL150	8"	152.4	166
CF-FW200	10"	203.2	191
CF-FW250	12"	254.0	255

Metal Gasket

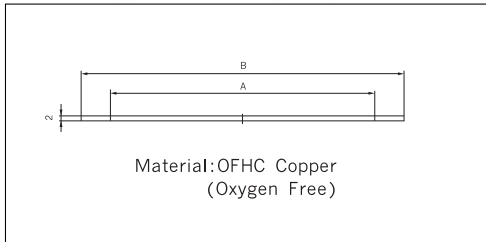

Technical Specification

ITEM No.	A	B
CF16	15	21.3
CF32	37	48.2
CF50	51	61.6
CF63	68.4	82.3
CF100	106.5	120.5
CF150	157.3	171.3
CF200	208.6	222.6
CF250	258.0	273.0

Welded Bellows

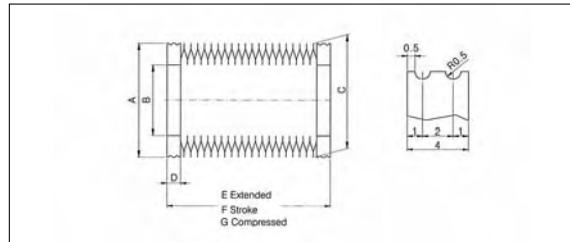

Technical Specification

ITEM No.	A(mm)	B(mm)	C(mm)	D(mm)
WB1-01	23	12.7	23	4
WB6-02	29.7	19	29.7	4
WB12-03	34.8	22	34.8	4
WB17-04	39	26	39	4
WB21-05	42	29.5	42	4
WB30-06	48	35	48	4
WB35-07	52	39.6	52	4
WB40-08	58.6	43.4	58.6	4
WB45-09	63.5	44.5	63.5	4
WB47-10	68.2	55.5	68.2	4
WB49-11	74.5	61.8	74.5	4
WB51-12	80.9	65	80.9	4
WB54-13	87.2	71.4	87.2	4
WB56-14	95.2	79.3	95.2	4
WB58-15	101	85	101	4
WB61-16	107	92	107	4

VACUUM ACCESSORIES

Flanges

CF Non Rotatable Bored Flanges

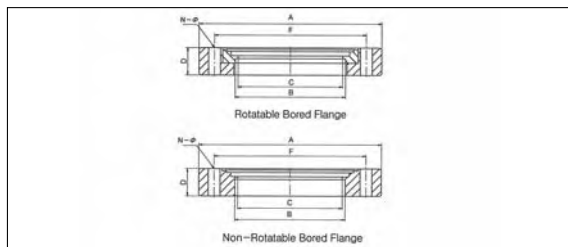

Dimensions · Specification

ITEM NO.	Flange Type(CF)		A(mm)	B(mm)	C(mm)	D(mm)	F(mm)	Hole N-Ø
	mm	inch						
CF 16NO	34	1 1/8	34	19.2	15.0	7.3	27.0	6-4.4
CF 35NO	70	2 3/4	70	40	38.5	12.7	58.7	6-6.6
CF 50NO	86	3 3/8	86	55	53	16.0	72.4	8-8.4
CF 63NO	114	4 1/2	114	63.8	61.0	17.5	92.1	8-8.4
CF 100NO	152	6	152	102.0	97.0	20.0	130.3	16-8.4
CF 150NO	203	8	203	150.5	148.5	22.0	181.0	20-8.4
CF 200NO	253	10	253	203.5	198.5	25.0	231.8	24-8.4
CF 250NO	305	12	305	255.5	250	28.0	284.0	32-8.4
CF 336NO	336	13 1/4	336	274.5	268.5	28.5	306.3	30-10.5

CF Double side Flanges

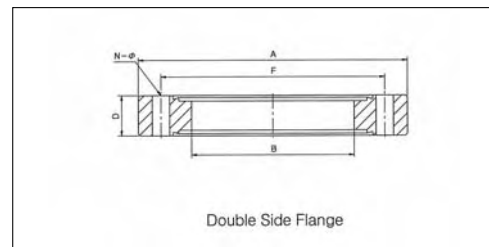

Dimensions · Specification

ITEM NO.	Flange Type(CF)		A(mm)	B(mm)	D(mm)	F(mm)	Hole N-Ø
	mm	inch					
CF 16DS-1	34	1 1/8	34	Blank	7.3	27.0	6-4.4
CF 16DS-2	34	1 1/8	34	10.0	7.3	27.0	6-4.4
CF 16DS-3	34	1 1/8	34	19.2	7.3	27.0	6-4.4
CF 35DS-1	70	2 3/4	70	Blank	12.7	58.7	6-6.6
CF 35DS-2	70	2 3/4	70	10	12.7	58.7	6-6.6
CF 35DS-3	70	2 3/4	70	20	12.7	58.7	6-6.6
CF 35DS-4	70	2 3/4	70	30	12.7	58.7	6-6.6
CF 35DS-5	70	2 3/4	70	38.5	12.7	58.7	6-6.6
CF 50DS-1	86	3 3/8	86	Blank	16.0	72.4	8-8.4
CF 50DS-2	86	3 3/8	86	10	16.0	72.4	8-8.4
CF 50DS-3	86	3 3/8	86	20	16.0	72.4	8-8.4
CF 50DS-4	86	3 3/8	86	30	16.0	72.4	8-8.4
CF 50DS-5	86	3 3/8	86	40	16.0	72.4	8-8.4
CF 50DS-6	86	3 3/8	86	51.0	16.0	72.4	8-8.4
CF 63DS-1	114	4 1/2	114	Blank	17.5	92.1	8-8.4
CF 63DS-2	114	4 1/2	114	30	17.5	92.1	8-8.4
CF 63DS-3	114	4 1/2	114	40	17.5	92.1	8-8.4
CF 63DS-4	114	4 1/2	114	50	17.5	92.1	8-8.4
CF 63DS-5	114	4 1/2	114	63.8	17.5	92.1	8-8.4
CF 100DS-1	152	6	152	Blank	20.0	130.3	16-8.4
CF 100DS-2	152	6	152	102.0	20.0	130.3	16-8.4
CF 150DS-1	203	8	203	Blank	22.0	181.0	20-8.4
CF 150DS-2	203	8	203	153.5	22.0	181.0	20-8.4
CF 200DS-1	253	10	253	Blank	25.0	231.8	24-8.4
CF 200DS-2	253	10	253	203.5	25.0	231.8	24-8.4
CF 250DS-1	305	12	305	Blank	28.0	284.0	32-8.4
CF 250DS-2	305	12	305	255.5	28.0	284.0	32-8.4
CF 336DS-1	336	13 1/4	336	Blank	28.5	306.3	30-10.5
CF 336DS-2	336	13 1/4	336	274.5	28.5	306.3	30-10.5

CF Rotatable Bored Flanges

Dimensions · Specification

ITEM NO.	Flange Type(CF)		A(mm)	B(mm)	C(mm)	D(mm)	F(mm)	Hole N-Ø
	mm	inch						
CF 16RO	34	1 1/8	34	19.2	15.0	7.3	27.0	6-4.4
CF 35RO	70	2 3/4	70	40	38.5	12.7	58.7	6-6.6
CF 50RO	86	3 3/8	86	55	53	16.0	72.4	8-8.4
CF 63RO	114	4 1/2	114	63.8	61.0	17.5	92.1	8-8.4
CF 100RO	152	6	152	102.0	97.0	20.0	130.3	16-8.4
CF 150RO	203	8	203	150.5	148.5	22.0	181.0	20-8.4
CF 200RO	253	10	253	203.5	198.5	25.0	231.8	24-8.4
CF 250RO	305	12	305	255.5	250	28.0	284.0	32-8.4
CF 336RO	336	13 1/4	336	274.5	268.5	28.5	306.3	30-10.5

WOOSUNG VACUUM SYSTEM LINE-UP





HEAD OFFICE

133-13, Namiocheon 1-gil, Nami-myeon, Seowon-gu
Cheongju-si, Chungcheongbuk-do, 362-813 Korea
TEL : +82-43-260-4310~2 FAX : +82-43-260-4313
<http://www.woovac.com> E-mail : sayou@woovac.com

SEOUL OFFICE

27-123, 198, Gurojungang-ro, Guro-gu, Seoul, 152-864 Korea
TEL : +82-2-2675-3073 FAX : +82-2-2631-5207

DAEJEON OFFICE

#3-114, 160, Daehwa-ro, Daedeok-gu, Daejeon, 306-754 Korea
TEL : +82-42-670-4100 FAX : +82-42-670-4108

POHANG STANDARD VACUUM

66-3, Hyeongsangangnam-ro 418beon-gil, Yeonil-eup, Nam-gu,
Pohang-si, Gyeongsangbuk-do, 790-884 Korea
TEL : +82-54-282-1617 FAX : +82-54-282-3436

- Some parts of contents in this catalogue may be changed without prior notice for better design and quality of products.
- All rights reserved.
- No part of this catalogue may be reproduced or copied in any form without prior permission from WOOSUNG VACUUM Co., LTD.
- Edited & published in 2014. 10.